

Contents

Vehicle Safety P. 2

Operation Guide P. 16

Maintenance P. 59

Troubleshooting P. 98

Information P. 116

Specifications P. 142

Welcome

Congratulations on your purchase of a new Honda vehicle. Your selection of a Honda makes you part of a worldwide family of satisfied customers who appreciate Honda's reputation for building quality into every product.

To ensure your safety and riding pleasure:

- Read this owner's manual carefully.
- Follow all recommendations and procedures contained in this manual.
- Pay close attention to safety messages contained in this manual and on the vehicle.

To protect your investment, we urge you to take responsibility for keeping your vehicle well serviced and maintained. Also, observe the break-in guidelines, and always perform the pre-ride inspection and other periodic checks in this manual.

When service is required, remember that your Honda dealer knows your vehicle best. If you have the required mechanical "know-how" and tools, you can purchase an official Honda Service Manual to help you perform many maintenance and repair tasks. ➤ P. 135

Read the warranty information thoroughly so that you understand the warranty coverage and that you are aware of your rights and responsibilities. ➤ P. 136

You may also want to visit our website at www.powersports.honda.com.
Happy riding!

A Few Words About Safety

Your safety, and the safety of others, is very important. Operating this vehicle safely is an important responsibility.

To help you make informed decisions about safety, we have provided operating procedures and other information on safety labels and in this manual. This information alerts you to potential hazards that could hurt you or others.

Of course, it is not practical or possible to warn you about all hazards associated with operating or maintaining a vehicle. You must use your own good judgment.

You will find important safety information in a variety of forms, including:

- Safety labels on the vehicle
- Safety Messages preceded by a safety alert symbol  and one of three signal words: DANGER, WARNING, or CAUTION.

These signal words mean:

DANGER

You **WILL** be **KILLED** or **SERIOUSLY HURT** if you don't follow instructions.

WARNING

You **CAN** be **KILLED** or **SERIOUSLY HURT** if you don't follow instructions.

CAUTION

You **CAN** be **HURT** if you don't follow instructions.

Other important information is provided under the following titles:

NOTICE

Information to help you avoid damage to your vehicle, other property, or the environment.

Vehicle Safety

This section contains important information for safe riding of your vehicle.
Please read this section carefully.

Safety Guidelines	P. 3
Safety Labels	P. 7
Safety Precautions	P. 9
Riding Precautions	P. 10
Accessories & Modifications	P. 14
Loading	P. 15

Safety Guidelines

Follow these guidelines to enhance your safety:

- Perform all routine and regular inspections specified in this manual.
- Stop the engine and keep sparks and flame away before filling the fuel tank.
- Do not run the engine in enclosed or partly enclosed areas. Carbon monoxide in exhaust gases is toxic and can kill you.

Always Wear a Helmet

It's a proven fact: helmets and protective apparel significantly reduce the number and severity of head and other injuries. So always wear an approved helmet and protective apparel. ➤ P. 9

Before Riding

Make sure that you are physically fit, mentally focused and free of alcohol and drugs. Check that you and your passenger are both wearing an approved helmet and protective apparel. Instruct your passenger on holding onto the grab rails or your waist, leaning with you in turns, and keeping their feet on the footpegs, even when the vehicle is stopped.

Take Time to Learn & Practice

Even if you have ridden other vehicles, practice riding in a safe area to become familiar with how this vehicle works and handles, and to become accustomed to the vehicle's size and weight.

Safety Guidelines

We recommend that all riders take a certified course approved by the Motorcycle Safety Foundation (MSF) or a state approved training course. New riders should start with the basic course, and even experienced riders will find the advanced course beneficial.

For information about the MSF training course nearest you, call the national toll-free number: (800) 446-9227.

Other riding tips can be found in the You and Your Motorcycle Riding Tips booklet that came with your vehicle.

Ride Defensively

Always pay attention to other vehicles around you, and do not assume that other drivers see you. Be prepared to stop quickly or perform an evasive maneuver.

Make Yourself Easy to See

Make yourself more visible, especially at night, by wearing bright reflective clothing, positioning yourself so other drivers can see you, signaling before turning or changing lanes, and using your horn when necessary.

Ride within Your Limits

Never ride beyond your personal abilities or faster than conditions warrant. Fatigue and inattention can impair your ability to use good judgment and ride safely.

Don't Drink or Use Drugs and Ride

Alcohol or drugs and riding don't mix. Even one alcoholic drink can reduce your ability to respond to changing conditions, and your reaction time gets worse with every additional drink. The same is true for drug use. Don't drink or use and ride, and don't let your friends do it either.

Keep Your Honda in Safe Condition

It's important to keep your vehicle properly maintained and in safe riding condition. Inspect your vehicle before every ride and perform all recommended maintenance. Never exceed load limits (➤ P. 15), and do not modify your vehicle or install accessories that would make your vehicle unsafe (➤ P. 14).

If You are Involved in a Crash

Personal safety is your first priority. If you or anyone else has been injured, take time to assess the severity of the injuries and whether it is safe to continue riding. Call for emergency assistance if needed. Also follow applicable laws and regulations if another person or vehicle is involved in the crash.

If you decide to continue riding, first turn the ignition switch to the OFF position, and evaluate the condition of your vehicle. Inspect for fluid leaks, check the tightness of critical nuts and bolts, and check the handlebar, control levers, brakes, and wheels. Ride slowly and cautiously. Your vehicle may have suffered damage that is not immediately apparent. Have your vehicle thoroughly checked at a qualified service facility as soon as possible.

Carbon Monoxide Hazard

Exhaust contains poisonous carbon monoxide, a colorless, odorless gas. Breathing carbon monoxide can cause loss of consciousness and may lead to death.

If you run the engine in confined or even partly enclosed area, the air you breathe could contain a dangerous amount of carbon monoxide.

Never run your vehicle inside a garage or other enclosure.

WARNING

Running the engine of your vehicle while in an enclosed or even partially enclosed area can cause a rapid build-up of toxic carbon monoxide gas.

Breathing this colorless, odorless gas can quickly cause unconsciousness and lead to death.

Only run your vehicle's engine when it is located in a well ventilated area outdoors.

Safety Labels

Safety and information labels on your vehicle provide important safety information and may warn you of potential hazards that could cause

serious injury. Read these labels carefully and don't remove them.

If a label comes off or becomes hard to read, contact your dealer for a replacement.

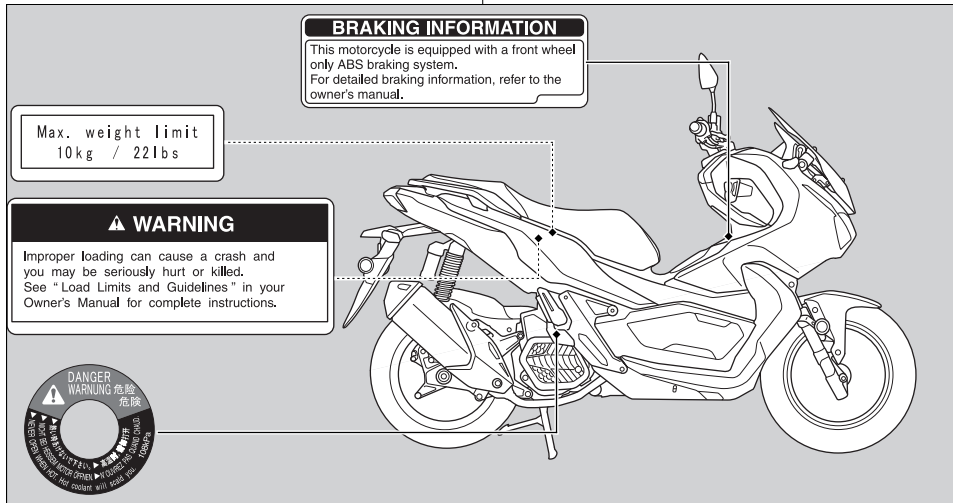

Max. weight limit
1.0kg / 2.0lbs

For your protection, always wear
your helmet while riding.
Read the owner's manual carefully.

TIRE INFORMATION			
Cold tire pressures		kPa	kg/cm ²
Up to maximum weight capacity	Front	200	2.00
	Rear	225	2.25
Up to 90kg(200lbs) load	Front	200	2.00
	Rear	225	2.25
Tire size	Front	110/80-14M/C 53P	
	Rear	130/70-13M/C 57P	
Min. recommend tire center tread depth.	Front	1.5mm (0.06in.)	
	Rear	2.0mm (0.08in.)	
Maximum weight capacity	166kg(366lbs)		
Read owner's manual.			

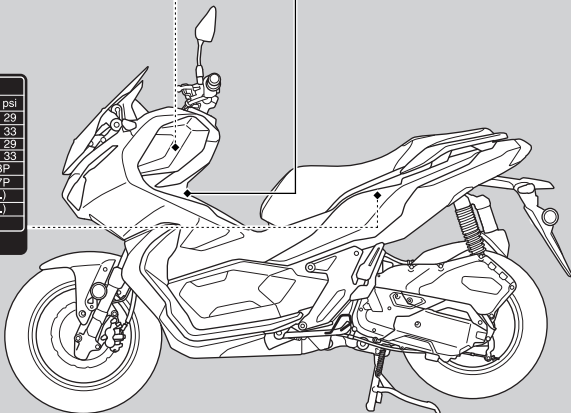

Safety Precautions

- Ride cautiously and keep your hands on the handlebar and feet on the floor.
- Keep passenger's hands onto the grab rails or your waist, passenger's feet on the footpegs while riding.
- Always consider the safety of your passenger, as well as other drivers and riders.

Protective Apparel

Make sure that you and any passenger are wearing an approved helmet, eye protection, and high-visibility protective clothing. Avoid wearing loose clothes that could get caught on any part of the vehicle. Ride defensively in response to weather and road conditions.

■ Helmet

Should be safety-standard certified, high-visibility, and correct size for your head

- Must fit comfortably but securely, with the chin strap fastened.
- Face shield with unobstructed field of vision or other approved eye protection

Look for a DOT (Department of Transportation) certification label on any helmet you buy.

WARNING

Not wearing a helmet increases the chance of serious injury or death in a crash.

Make sure that you and any passenger always wear an approved helmet and protective apparel.

■ Gloves

Full-finger leather gloves with high abrasion resistance

Riding Precautions

■ Boots or Riding Shoes

Sturdy boots with non-slip soles and ankle protection

■ Jacket and Pants

Protective, highly visible, long-sleeved jacket and durable long pants for riding (or a protective suit)

Riding Precautions

Break-in Period

During the first 300 miles (500 km) of running, follow these guidelines to ensure your vehicle's future reliability and performance.

- Avoid full-throttle starts and rapid acceleration.
- Avoid hard braking.
- Ride conservatively.

Brakes

Observe the following guidelines:

- Avoid excessively hard braking.
 - ▶ Sudden braking can reduce the vehicle's stability.
 - ▶ Where possible, reduce speed before turning; otherwise you risk sliding out.
- Exercise caution on low traction surfaces.
 - ▶ The tires slip more easily on such surfaces and braking distances are longer.

- Avoid continuous braking.
 - ▶ Repeated braking, such as when descending long, steep slopes can seriously overheat the brakes, reducing their effectiveness.
- For full braking effectiveness, operate both the front and rear brakes together.

■ **Anti-lock Brake System (ABS) on Front Wheel**

This model equipped with an Anti-lock Brake System (ABS) designed to help prevent the front brake from locking up during hard braking.

- There is no ABS function to the rear wheel.
- ABS does not reduce braking distance. In certain circumstances, ABS may result in a longer stopping distance.
- ABS does not function at speeds below 6 mph (10 km/h).
- The front brake lever may recoil slightly when applying the brakes. This is normal.

- Always use the recommended front/rear tires to ensure correct ABS operation.

■ **Wet or Rainy Conditions**

Road surfaces are slippery when wet, and wet brakes further reduce braking efficiency. Exercise extra caution when braking in wet conditions.

If the brakes get wet, apply the brakes while riding at low speed to help them dry.

Parking

- Park on a firm, level surface.
- If you must park on a slight incline or loose surface, park so that the vehicle cannot move or fall over.
- Make sure that high-temperature parts cannot come into contact with flammable materials.
- Do not touch the engine, muffler, brakes and other high-temperature parts until they cool down.
- To reduce the likelihood of theft, always lock the handlebar, lock the ignition switch (▶ P. 41) and leave your vehicle while taking the Honda SMART Key with you. Deactivate the Honda SMART Key system if necessary. ▶ P. 36
Use of an anti-theft device is also recommended.

■ Parking with the Side Stand or Center Stand

1. Stop the engine.

2. Using the side stand

Push the side stand down.

Slowly lean the vehicle to the left until its weight rests on the side stand.

Using the center stand

To lower the center stand, stand on the left side of the vehicle.

Hold the left handle grip and the grab rail.

Press down on the tip of the center stand with your right foot and, simultaneously, pull up and back.

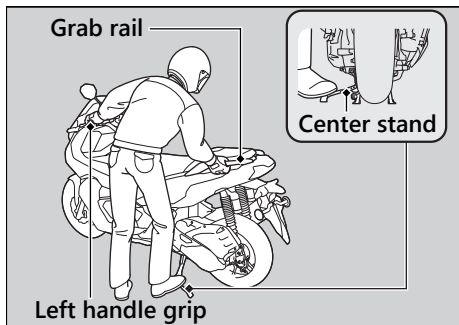

3. Turn the handlebar fully to the left.
 - ▶ Turning the handlebar to the right reduces stability and may cause the vehicle to fall.
4. Turn the ignition switch to the LOCK position (➤ P. 34) and lock the ignition switch (➤ P. 41).

Refueling and Fuel Guidelines

Follow these guidelines to protect the engine, fuel system and catalytic converter:

- Use only unleaded gasoline.
- Use recommended octane number. Using lower octane gasoline will result in decreased engine performance.
- Do not use fuels containing a high concentration of alcohol. ➤ P. 134
- Do not use stale or contaminated gasoline or an oil/gasoline mixture.
- Avoid getting dirt or water in the fuel tank.

Accessories & Modifications

We strongly advise that you do not add any accessories that were not specifically designed or approved for your vehicle by Honda or make modifications to your vehicle from its original design. Doing so can make it unsafe. Modifying your vehicle may also void your warranty and make your vehicle illegal to operate on public roads. Before deciding to install accessories on your vehicle be certain the modification is safe and legal.

⚠️ WARNING

Improper accessories or modifications can cause a crash in which you can be seriously hurt or killed.

Follow all instructions in this owner's manual regarding accessories and modifications.

Do not pull a trailer with, or attach a sidecar to, your vehicle. Your vehicle was not designed for these attachments, and their use can seriously impair your vehicle's handling.

Loading

- Carrying extra weight affects your vehicle's handling, braking and stability.
Always ride at a safe speed for the load you are carrying.

- Avoid carrying an excessive load and keep within specified load limits.

Maximum weight capacity / Maximum luggage weight 📄 P. 142

- Tie all luggage securely, evenly balanced and close to the center of the vehicle.
- Do not place objects near the lights or the muffler.

WARNING

Overloading or improper loading can cause a crash and you can be seriously hurt or killed.

Follow all load limits and other loading guidelines in this manual.

Parts Location

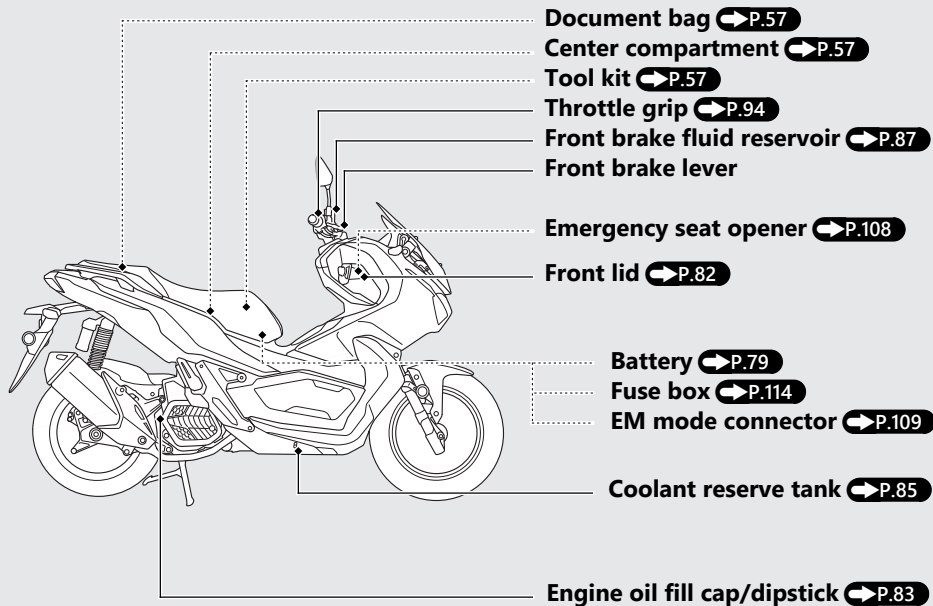

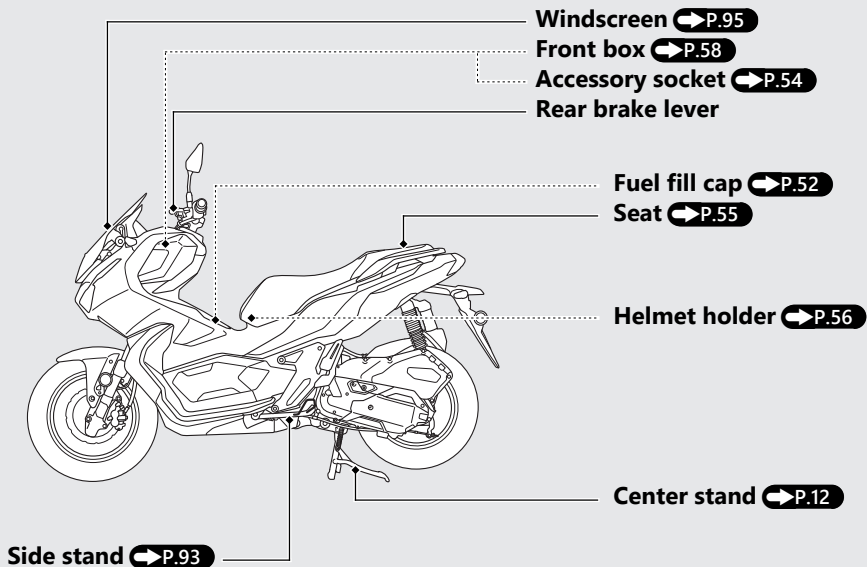

Instruments

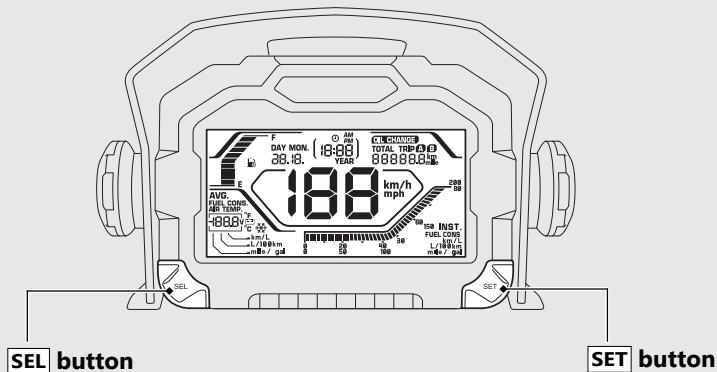

Display Check

When the ignition switch is turned to the ON position, initial animation will show. If any part of these displays does not come on when it should, have your dealer check for problems.

Date

To set the date: ➔ P.25

Clock (12-hour display)

To set the clock: ➔ P.26

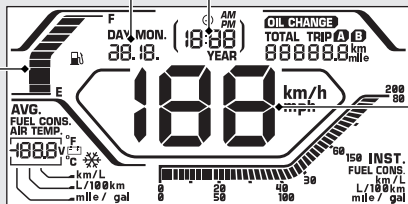

Fuel gauge

Remaining fuel when only 1st (E) segment left approximately 0.26 US gal (1.0 L).

This segment flashes when the fuel decreases further.

If the fuel gauge indicator flashes in a repeat pattern or turns off: ➔ P.105



Speedometer

Instruments (Continued)

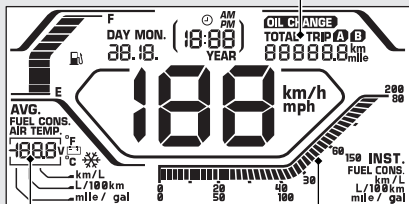

Odometer [TOTAL] ➔ P.22 /
Tripmeter [TRIP A/B] ➔ P.22

Current fuel mileage [INST.
FUEL CONS.]

Battery voltage meter [V] ➔ P.22 /
Average fuel mileage [AVG. FUEL CONS.] ➔ P.22 /
Air temperature gauge [AIR TEMP.] ➔ P.22

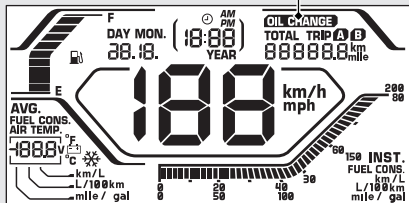

OIL CHANGE indicator

The indicator is turned on whenever the running distance reaches the programmed oil change interval.

When the running distance reaches about 600 miles (966 km):

Reset the indicator for the 1st time.

When the running distance reaches about every 4,000 miles (6,440 km) after the 1st time resetting:

Reset the indicator whenever it is turned on.

After changing the engine oil, be sure to reset the indicator.

To reset the indicator, press and hold the **SET** button while turning the ignition switch to the ON position, and keep holding the **SET** button for more than 3 seconds.

The indicator does not go off until it is reset.

If the oil is changed before the oil change indicator comes on, be sure to reset the oil change indicator after changing the oil.

When resetting the indicator during no indication, the indicator will appear for 2 seconds, then disappear.

Instruments *(Continued)*

Odometer

Total distance ridden.

When "-----" is displayed, go to your dealer for service.

Tripmeter A/B

Distance ridden since tripmeter was reset.

- ▶ To reset tripmeter, press and hold **SET** button while tripmeter displayed. When to reset tripmeter, the average fuel mileage is also reset.

Air temperature gauge

Shows ambient temperature.

Display range: 14 to 122°F (-10 to 50°C)

- Below 14°F (-10°C): "----" is displayed
- Above 122°F (50°C): 122°F (50°C) flashes

❄ comes on when air temperature is below 38°F (3°C), and goes off when air temperature reaches 41°F (5°C) after ❄ comes on.

Battery voltage

Current battery voltage.

Average fuel mileage A/B

Displays the average fuel mileage since the selected tripmeter was reset.

The average fuel mileage will be calculated based on value displayed on the tripmeter (A or B) selected. When each tripmeter is reset, each average fuel mileage will also reset.

Display range: 0.0 to 199.9 mile/gal (km/L)

Less than 0.1 mile/gal (km/L): "0.0" is displayed

More than 199.9 mile/gal (km/L): "199.9" is displayed

- When the tripmeter A or B is reset: "---.-" is displayed.

When "---.-" is displayed except for the above-mentioned cases, go to your dealer for service.

Switching the Display

The **SEL** button switches among the odometer, tripmeter A and tripmeter B.

Also **SEL** button switches among the battery voltage meter, air temperature gauge and average fuel mileage.

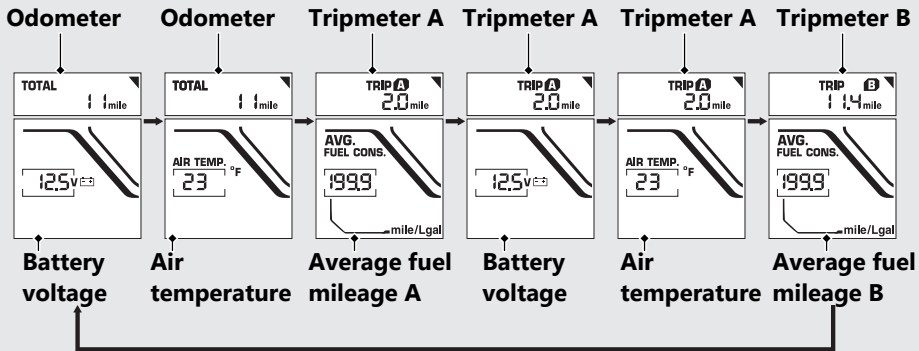

→ Press the **SEL** button

Instruments *(Continued)*

Display Setting

The following items change sequentially:

- Date setting
- Clock setting
- Backlight brightness adjustment
- Activating/deactivating of tripmeter A and average fuel mileage A automatic reset mode
- Changing of speed and mileage unit
- Changing of air temperature unit
- Changing of fuel mileage meter unit

The following moves the ordinary display at display setting.

- The switch is not pressed for about 30 seconds
- Turn the ignition switch to the OFF position and then to the ON position

To complete the setting for date and clock, it is necessary to finalise the minute in the clock setting or turn the ignition switch to the OFF position.

➡ Press and hold **SEL** button and **SET** button

↪ Press **SET** button

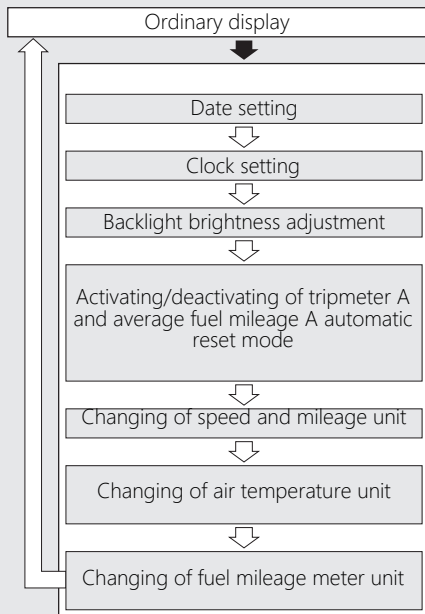

1 Date setting:

- 1 Turn the ignition switch to the ON position.
- 2 Press and hold the **SEL** button and **SET** button, the year digits start flashing.
- 3 Press the **SEL** button until the desired year is displayed.
 - ▶ Press and hold the **SEL** button to advance the year fast.



- 4 Press the **SET** button. The month digits start flashing.



- 5 Press the **SEL** button until the desired month is displayed.
 - ▶ Press and hold the **SEL** button to advance the month fast.



- 6 Press the **SET** button. The day digits start flashing.

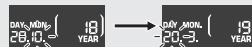

- 7 Press the **SEL** button until the desired day is displayed.
 - ▶ Press and hold the **SEL** button to advance the day fast.



- 8 Press the **SET** button. The date is set, and the display moves to the clock setting.

Instruments (Continued)

2 Clock setting:

- 1 Press the **SEL** button until the desired hour is displayed.
 - ▶ When the display changes from 11 to 12, AM/PM will switch at the same time.
 - ▶ Press and hold the **SEL** button to advance the hour fast.



- 2 Press the **SET** button. The minute digits start flashing.



- 3 Press the **SEL** button until the desired minute is displayed.
 - ▶ Press and hold the **SEL** button to advance the minute fast.



- 4 Press the **SET** button. The clock is set, and the display moves to the backlight brightness adjustment.

3 Backlight brightness adjustment:

You can adjust the brightness to one of five levels.

- 1 Press the **SEL** button. The brightness is switched.

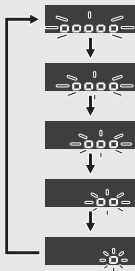

- 2 Press the **SET** button. The brightness level is set, and the display moves to the activating/deactivating of tripmeter A and average fuel mileage A automatic reset mode.

4 To activate/deactivate of tripmeter A and average fuel mileage A automatic reset mode:

You can activate or deactivate the automatic reset mode by refueling after 1st (E) segment of the fuel gauge start flashing. Activation is initially set.

- 1 Press the **SEL** button to select "On" (activate) or "OFF" (deactivate) in the automatic reset mode.



- 2 Press **SET** button. The activation/deactivation of automatic reset mode is set, and then the display moves to changing of speed and mileage unit..

Instruments *(Continued)*

5 Changing of speed and mileage unit:

- 1 Press **SET** switch, the speed and mileage unit start flashing fast.
- 2 Press **SEL** switch to select either "km/h" and "km" or "mph" and "mile".

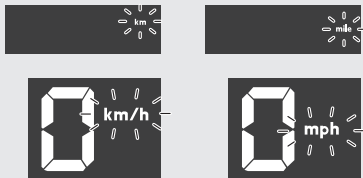

- 3 Press **SET** switch. The speed and mileage unit is set, and then the display moves to the changing of air temperature unit.

6 Changing of air temperature unit:

- 1 Press **SET** switch, the temperature unit start flashing fast.
- 2 Press **SEL** switch to select "°C" and "°F".
- 3 Press **SET** switch. The air temperature unit is set, and then the display moves to the changing of fuel mileage meter unit. (fuel mileage meter unit start flashing.)

7 Changing of fuel mileage meter unit:

- 1 Press **SET** switch, the fuel mileage meter unit start flashing fast.
- 2 When the speed and mileage unit selecting the "km/h" and "km".
Press **SEL** switch to select "km/L" or "L/100km".



When the speed and mileage unit selecting the "mph" and "mile".

The fuel mileage is indicated by "mile/gal".

- 3 To end the selection, press **SET** switch.

The established setting can also be set by turning the ignition switch to the OFF position.

The control is automatically switched from the setting mode to the ordinary display if the switch is not pressed for about 30 seconds. Even in this case, setting is maintained.

Indicators

If one of these indicators does not come on when it should, have your dealer check for problems.

 **High beam indicator**

 **High coolant temperature indicator**

If it comes on while riding:

 **P.100**

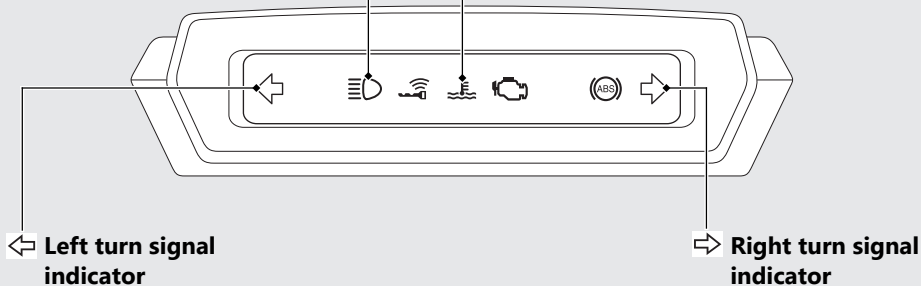

 **PGM-FI (Programmed Fuel Injection) malfunction indicator lamp (MIL)**

Comes on briefly when the ignition switch is turned ON position with engine stop switch in the  (Run) position..

If it comes on while engine is running:  **P.101**

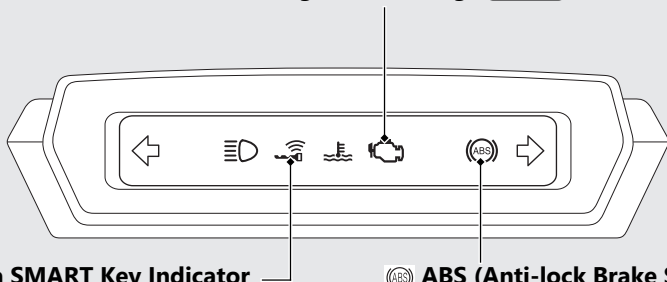

 **Honda SMART Key Indicator**

Comes on when vehicle and Honda SMART Key verification is complete, and the ignition switch can be operated.

Goes off when the ignition switch is turned ON position.

When the Honda SMART Key Indicator

Flashes:  **P.103**

 **ABS (Anti-lock Brake System) indicator**

Comes on when the ignition switch is turned to the ON position. Goes off when your speed reaches approximately 6 mph (10 km/h).

If it comes on while riding:  **P.102**

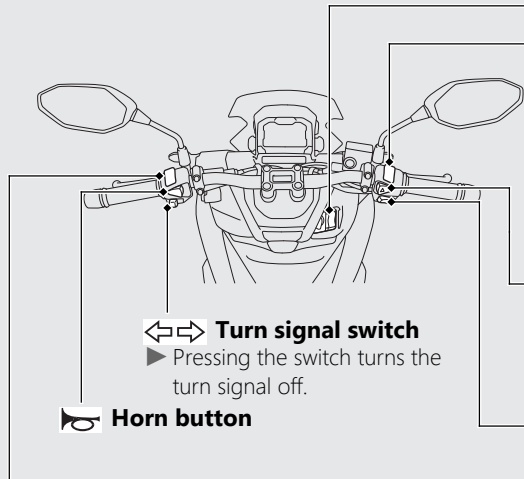

Switches



 **Turn signal switch**
▶ Pressing the switch turns the turn signal off.

 **Horn button**

Headlight dimmer switch

-  : High beam
-  : Low beam

Engine stop switch

Should normally remain in the  (Run) position.

- ▶ In an emergency, switch to the  (Stop) position (the starter motor will not operate) to stop the engine.

 **Hazard switch**

The hazard signal is on. Switchable when the ignition switch is on.

 **Start button**

Ignition switch

Switches the electrical system on/off, locks the steering, and operates the fuel lid and seat opener switch.

To unlock the ignition switch:

➔ P.40

ON Turns electrical system on for starting/riding.

SEAT FUEL Operates the fuel lid and seat opener switch.

OFF Turns engine off.

LOCK Locks steering.

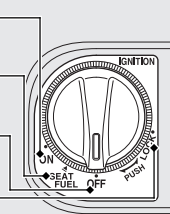

Switches *(Continued)*

Steering Lock

Lock the steering when parking to help prevent theft.

A U-shaped wheel lock or similar device is also recommended.

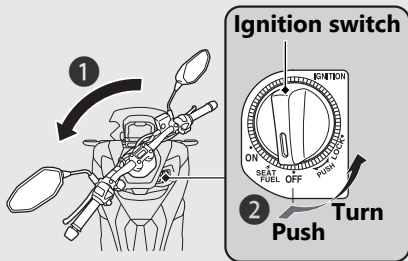

Locking

- 1 Turn the handlebar all the way to the left or right.
- 2 Push the ignition switch down, and turn it to the LOCK position.
 - ▶ To unlock the ignition switch ➔ **P.40**
 - ▶ Jiggle the handlebar if the lock is difficult to engage.
- 3 Lock the ignition switch.

Unlocking

Push the ignition switch in, and turn it to the OFF position.

- ▶ To unlock the ignition switch ➔ **P.40**

Honda SMART Key System

The Honda SMART Key system allows you to operate the main switch without inserting a key into a keyhole.

The system runs a two-way authentication between the vehicle and the Honda SMART Key to verify if it is the registered Honda SMART Key.

The Honda SMART Key system uses low-intensity radio waves. It may affect medical equipment such as a cardiac pacemaker.

Honda SMART Key System *(Continued)*

Switching the Honda SMART Key System

To switch the Honda SMART Key system to activation or deactivation

Press the ON/OFF button until the Honda SMART Key LED changes color.

To check the Honda SMART Key system status

Lightly press the ON/OFF button. The Honda SMART Key LED will show the status.

When the Honda SMART Key LED is:

Green: Honda SMART Key system authentication can be performed.

Red: (inactive) Honda SMART Key system authentication cannot be performed.

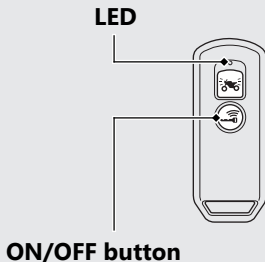

Operating Range

The operating range varies when the ignition switch is locked or unlocked.

The Honda SMART Key system uses low-intensity radio waves. Therefore, the operating range may be wider or narrower, or the Honda SMART Key system may not work properly in the following situations:

- When the Honda SMART Key battery is depleted.
- When there are facilities nearby that generate strong radio waves or noise, such as TV towers, power stations, radio stations, or airports.
- When you carry the Honda SMART Key with a laptop or wireless communication device such as a radio or mobile phone.
- When the Honda SMART Key comes into contact with or is covered by metal objects.

When the ignition switch is unlocked:

The system can be operated within the shaded area shown in the illustration.

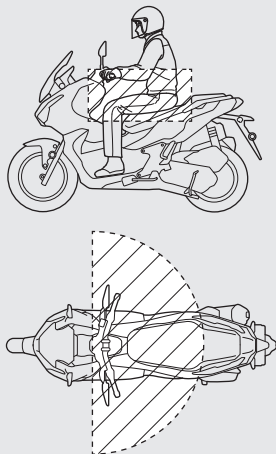

Honda SMART Key System *(Continued)*

When the ignition switch is locked:

The system can be operated within the shaded area shown in the illustration.

About 6.6 ft (2 m)

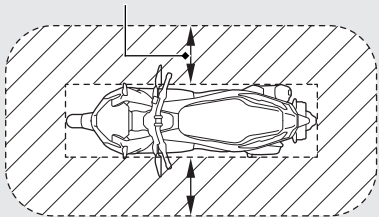

Anyone can unlock the ignition switch and start the engine if your Honda SMART Key is within operating range of your vehicle, even if you are on the other side of a wall or window. If you are away from your vehicle but your Honda SMART Key is still within operating range, deactivate the Honda SMART Key system.

To switching the Honda SMART Key system ➔ P.36

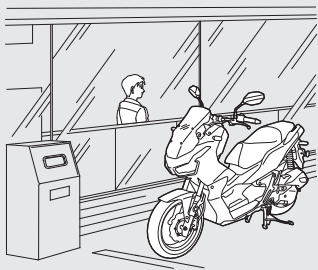

Anyone in possession of the Honda SMART Key can perform the following operations if the Honda SMART Key is within operating range:

- Starting the engine
- Unlocking the ignition switch
- Releasing the seat lock
- Opening the fuel lid
- Unlocking the steering lock

You should always keep the Honda SMART Key on your person after you get on and off the vehicle or while riding.

Do not place the Honda SMART Key in the center compartment or front box.

If the ignition switch is in the ON position, the vehicle can be operated even by a person who does not have a verified Honda SMART Key.

Whenever you leave your vehicle, lock the steering and lock the ignition switch.



Make sure the ignition switch ring goes off and all turn signals flash once at this time.

Honda SMART Key System (Continued)

Switching the ignition switch

To Unlock the Ignition Switch

- 1 Make sure that the Honda SMART Key is activated. **➡ P.36**
- 2 To authenticate the Honda SMART Key system, push the ignition switch.
 - ▶ When properly authenticated and the ignition switch is unlocked, the Honda SMART Key indicator and ignition switch ring come on.
- 3 Turn the ignition switch to the ON position while the Honda SMART Key indicator comes on.
 - ▶ If you do not turn the ignition switch to the ON position within 20 seconds after pushing in the ignition switch in, the Honda SMART Key indicator and ignition switch ring will go off, the turn signals flash 1 time, and then the ignition switch will be locked.

When the Honda SMART Key system does not work properly **➡ P.106**

If someone without the Honda SMART Key tries to turn the ignition switch, the ignition switch rotates freely. If you notice the ignition switch is in a different position, turn the ignition switch to the original position (OFF or LOCK).

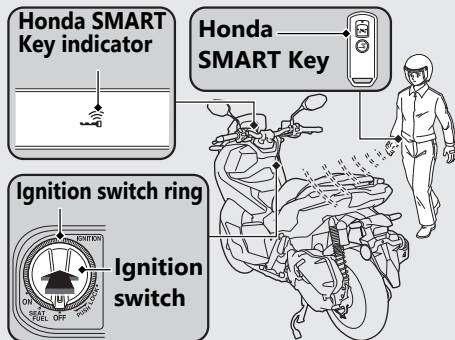

To Lock the Ignition Switch

- 1 Turn the ignition switch to the SEAT FUEL, OFF or LOCK position.
- 2 Lock the ignition switch by doing one of the following:
 - Leave the operating range with the Honda SMART Key. ➔P.37
 - Push the ignition switch.
 - Wait for approximately 20 seconds after turning the ignition switch from ON to SEAT FUEL, OFF or LOCK.
 - Switch the Honda SMART Key system to inactive. ➔P.36
- 3 Make sure that the Honda SMART Key indicator and ignition switch ring go off, the turn signals flash once. This indicates that the ignition switch is locked.

When the Honda SMART Key system does not work properly ➔P.106

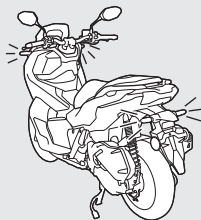
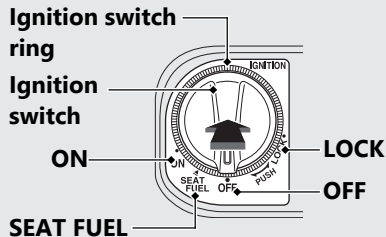

Honda SMART Key System *(Continued)*

Always make sure the ignition switch position is in the OFF or LOCK position when you leave your vehicle.

When the ignition switch is locked in the SEAT FUEL position, the ignition switch can be turned OFF only once.

When the ignition switch is locked in the OFF position, the steering cannot be locked. To lock the steering, unlock the ignition switch.

Answer Back System

The answer back system is a device to find the location of your vehicle. When the immobilizer is active and you press the ANSWER BACK button on the Honda SMART Key with the ignition switch in the OFF or LOCK position, the turn signals light, and the ignition switch ring lights, informing you of your vehicle's location. The ignition switch ring will light for about 1 minute.

The answer back system uses low-intensity radio waves. It may affect medical equipment such as a cardiac pacemaker.

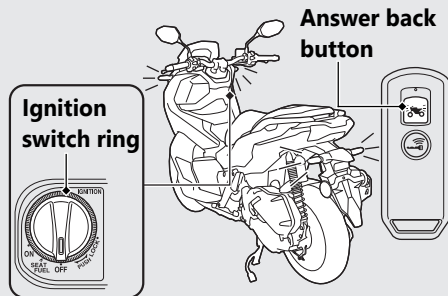

Answer Back System *(Continued)*

Operation

Press the answer back button on the Honda SMART Key.

- ▶ The answer back system will not function when the ignition switch is ON position.

If the ignition switch is left the OFF or LOCK position for more than 10 days, the answer back system will no longer operate. When the system is active and the vehicle receives a signal from pressing the answer back button, system activation will be extended for 10 days.

To reset the system, unlock the ignition switch and turn the ignition switch ON position once.

- ▶ To unlock the ignition switch  **P.40**

When the battery in the vehicle is weak, the answer back system may not function.

Rear Brake Lock

Be sure the rear brake lock is applied while starting and warming up the engine.

Locking

Squeeze the rear brake lever and set the rear brake lock lever.

- ▶ The rear brake lock will not function if the rear brake is not adjusted properly. ➤ P. 90

Rear brake
lock lever

Rear brake
lever

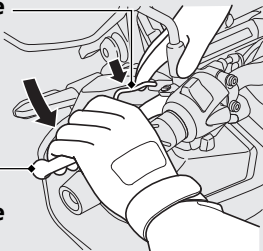

Unlocking

Squeeze the rear brake lever.

- ▶ Before riding, make sure that the rear brake lock is fully released so there is no drag on the rear wheel.

Rear brake
lever

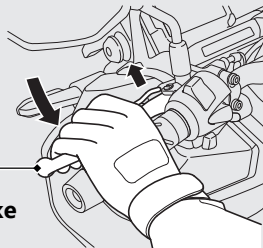

Starting the Engine

Start your engine using the following procedure, regardless of whether the engine is cold or warm.

This vehicle is equipped with a side stand ignition cut-off system.

- ▶ If the side stand is down, the engine cannot be started.
- ▶ If you lower the side stand with the engine running, it will automatically shut off.

This vehicle is equipped with a Honda SMART Key system. Always keep Honda SMART Key on you when you ride the vehicle.  **P.37**

If the engine of this vehicle is stopped while the ignition switch is in the ON position, authentication will be disabled after a certain amount of time or if you leave the authentication range. Restart the engine by performing step **3** - **5** under the starting procedure.

NOTICE

- If the engine does not start within 5 seconds, turn the ignition switch to the OFF position and wait 10 seconds before trying to start the engine again to recover battery voltage.
- Extended fast idling and revving the engine can damage the engine, and the exhaust system.
- The engine will not start if the throttle is fully open.
- If the vehicle is over-turned, you must first turn the ignition switch to the OFF position and then inspect the vehicle carefully.

- 1 Place the vehicle on its center stand.
- 2 Turn the ignition switch to the ON position.
 - ▶ To unlock the ignition switch. ➔ P.40

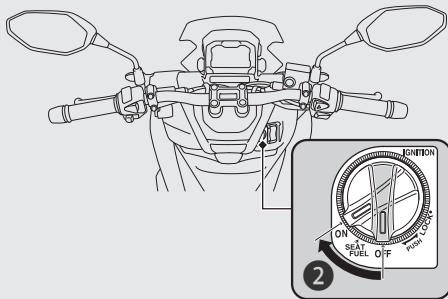

- 3 Make sure the engine stop switch is in the  (Run) position.
- 4 Lock the rear wheel by squeezing the rear brake lever and setting the rear brake lock lever.
 - ▶ The starter motor will only work when the rear brake lever is squeezed and the side stand is up.

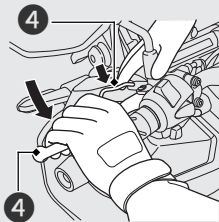

Starting the Engine *(Continued)*

- 5 With the throttle completely closed, press the start button.

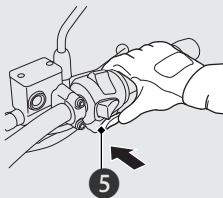

If you cannot start the engine:

- 1 Place the vehicle on its center stand and squeeze the rear brake lever.
- 2 Open the throttle slightly (about 0.1 in (3 mm), without freeplay), press the start button.

About 0.1 in (3 mm), without freeplay

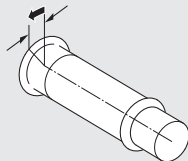

If the engine does not start:

- ① Open the throttle fully and press the start button for 5 seconds.
- ② Repeat the normal starting procedure.
- ③ If the engine starts, open the throttle slightly if idling is unstable.
- ④ If the engine does not start, wait 10 seconds before trying steps ① & ② again.

If Engine Will Not Start ➡ P.99

Riding

Starting the Vehicle

① Push the vehicle forward off the center stand.

- ▶ Lock the rear brake lock.
- ▶ Keep throttle closed.

Make sure the side stand and center stand are up.

② Get on the vehicle.

- ▶ Mount the vehicle from the left side, keeping at least one foot on the ground.

③ Release the rear brake lock.

④ Acceleration and deceleration

To accelerate: Open the throttle slowly.

To decelerate: Close the throttle.

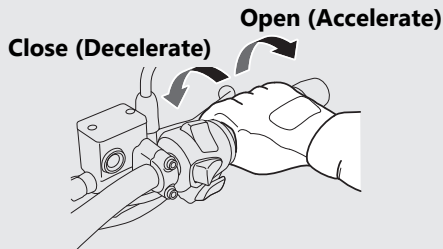

Braking

Close the throttle and apply the front and rear brake levers together.

Do not apply the brake lock while riding. It may cause the wheel to lock, reducing control of the vehicle.

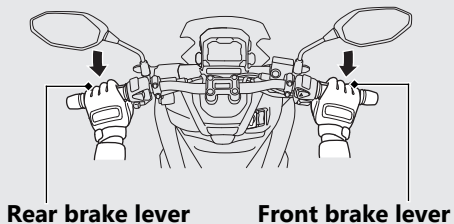

Refueling

Fuel type: Unleaded gasoline only

Recommended fuel octane number:

Pump Octane Number (PON) 86 or higher.

Tank capacity: 2.11 US gal (8.0 L)

Refueling and Fuel Guidelines ➔ P.13

Opening the Fuel Fill Cap

- 1 Turn the ignition switch to the position of SEAT FUEL.
 - ▶ To unlock the ignition switch ➔ P.40
- 2 Push the FUEL side of the fuel lid and seat opener switch.
 - ▶ The fuel lid opens.

Fuel lid

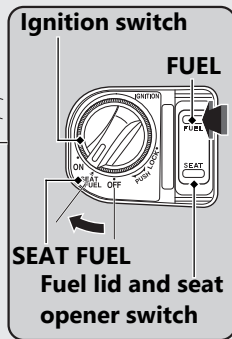
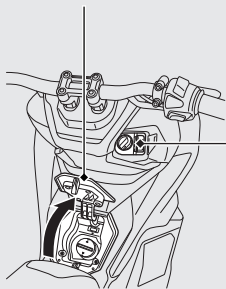

- 3 Turn the fuel fill cap counterclockwise and remove the fuel fill cap.

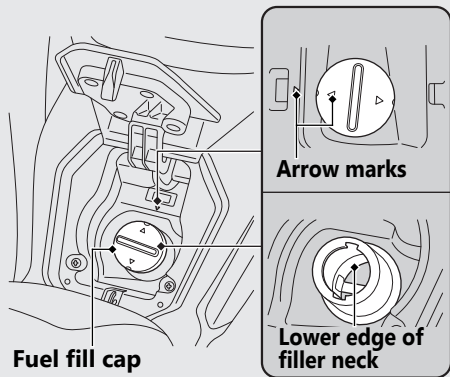

Do not fill with fuel above the lower edge of the filler neck.

Closing the Fuel Fill Cap

- 1 Install and tighten the fuel fill cap firmly by turning it clockwise.
 - ▶ Make sure that the arrow marks on the fuel fill cap and fuel tank are aligned.
- 2 Close the fuel lid until it locks.
 - ▶ Make sure that the fuel lid is closed securely.

⚠WARNING

Gasoline is highly flammable and explosive. You can be burned or seriously injured when handling fuel.

- Stop the engine, and keep heat, sparks, and flame away.
- Handle fuel only outdoors.
- Wipe up spills immediately.

Accessory Socket

The accessory socket is located in the front box. **➔ P.58**

Use accessory devices at your own risk. In no event shall Honda be liable for any damages to your accessory device when in use.

Open the cover to access the socket.

Rated capacity is

12W (12V, 1A).

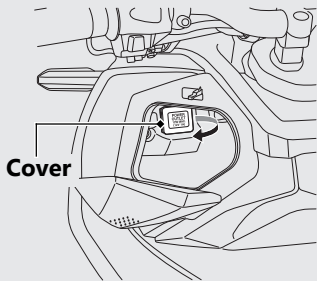

- ▶ To prevent the battery from becoming weak (or dead), keep the engine running while drawing current from the socket.
- ▶ Set the headlight on low beam while the socket is in use. The battery may run down or cause damage to the socket.
- ▶ To prevent entry of foreign matter into the socket, be sure to close the cover when the socket is not used.

NOTICE

- Using any heat-generating accessory or improperly rated accessory can damage the socket.
- Do not use the socket in wet conditions, when or while washing or any other wet conditions as these will damage the socket.

Storage Equipment

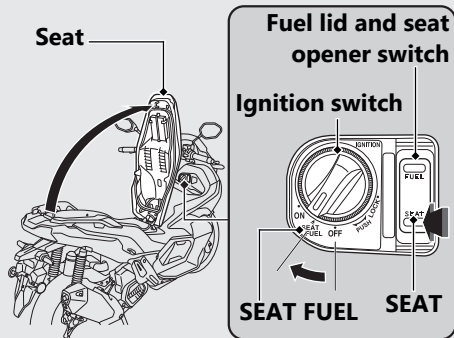

Seat Open

- 1 Turn the handlebar pointed straight ahead.
- 2 Turn the ignition switch to the position of SEAT FUEL.
 - ▶ To unlock the ignition switch → P.40
- 3 Push the SEAT side of the fuel lid and seat opener switch.
- 4 Open the seat.

Seat Close

Close and push down on the rear of the seat until it locks. Make sure that the seat is locked securely by pulling it up lightly. Take care not to lock your key in the compartment under the seat.

Storage Equipment *(Continued)*

Helmet Holder

The helmet holder is located under the seat. A helmet set wire is in the tool kit.

- ▶ Use the helmet holder only when parked.

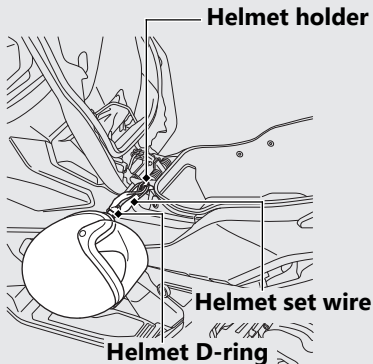

⚠ WARNING

Riding with a helmet attached to the holder can interfere with your ability to safely operate the vehicle and could lead to a crash in which you can be seriously hurt or killed.

Use the helmet holder only while parked. Do not ride with a helmet secured by the holder.

A helmet can be stored in the center compartment.

Set in the front of the helmet forward.

- ▶ Some helmets may not fit in the compartment due to their size or design.

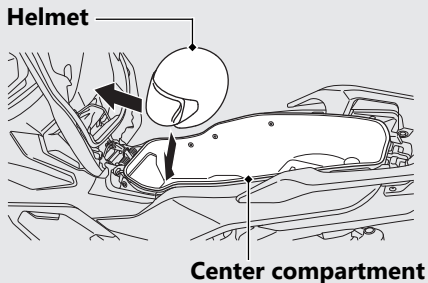

Center Compartment

Never exceed the maximum weight limit.

Maximum Weight: 22 lb (10 kg)

- ▶ Do not store any items that are flammable or susceptible to heat damage.
- ▶ Do not store valuables or fragile articles.

Tool Kit/Document Bag

The tool kit and document bag are located underside of the seat by the rubber strap.

Document bag

Tool kit

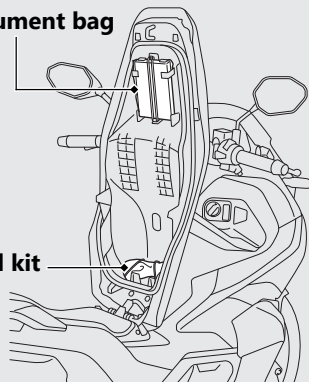

Storage Equipment *(Continued)*

Front Box

Open

Push the front box lid, then open the front box lid.

Close

Close the front box lid by pressing the front box lid.

The maximum allowable load in the front box shall be no more than

2.0 lb (1.0 kg)

Make sure that the front box lid is closed securely.

- ▶ Do not store valuables or fragile articles.

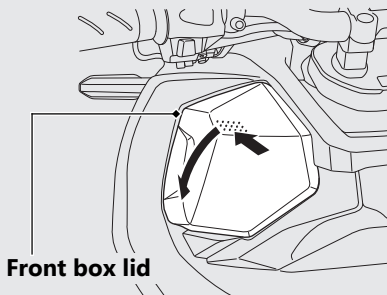

Maintenance

Please read "Importance of Maintenance" and "Maintenance Fundamentals" carefully before attempting any maintenance. Refer to "Specifications" for service data.

Importance of Maintenance	P. 60	Throttle	P. 94
Maintenance Schedule	P. 62	Other Adjustments	P. 95
Maintenance Record	P. 65	Adjusting the Windscreen Height	P. 95
Maintenance Fundamentals	P. 66	Other Replacement	P. 96
Tool	P. 78	Replacing the Honda SMART Key Battery.....	P. 96
Removing & Installing Body Components ..	P. 79		
Battery	P. 79		
Battery Cover.....	P. 80		
Clip	P. 81		
Front Lid.....	P. 82		
Engine Oil	P. 83		
Coolant	P. 85		
Brakes	P. 87		
Side Stand	P. 93		

Importance of Maintenance

Importance of Maintenance

Keeping your vehicle well-maintained is absolutely essential to your safety and to protect your investment, obtain maximum performance, avoid breakdowns, and reduce air pollution. Maintenance is the owner's responsibility. Be sure to inspect your vehicle before each ride, and perform the periodic checks specified in the Maintenance Schedule.

➤ P. 62

WARNING

Improperly maintaining your vehicle or failing to correct a problem before you ride can cause a crash in which you can be seriously hurt or killed.

Always follow the inspection and maintenance recommendations and schedules in this owner's manual.

For information about the exhaust emission and noise emission requirements of the U.S. Environmental Protection Agency (EPA), and the California Air Resources Board (CARB). ➤ P. 129

Maintenance, replacement or repair of the emission control devices and systems may be performed by any vehicle repair establishment or individual using parts that are "certified" to EPA standards.

Maintenance Safety

Always read the maintenance instructions before you begin each task, and make sure that you have the tools, parts, and skills required. We cannot warn you of every conceivable hazard that can arise in performing maintenance. Only you can decide whether or not you should perform a given task.

Follow these guidelines when performing maintenance.

- Stop the engine and turn the ignition switch to the OFF position.
- Place your vehicle on a firm, level surface using the side stand, center stand or a maintenance stand to provide support.
- Allow the engine, muffler, brakes, and other high-temperature parts to cool before servicing as you can get burned.
- Run the engine only when instructed, and do so in a well-ventilated area.

Maintenance Schedule

The maintenance schedule specifies the maintenance requirements necessary to ensure safe, dependable performance, and proper emission control.

Maintenance work should be performed in accordance with Honda's standards and specifications by properly trained and equipped technicians. Your dealer meets all of these requirements. All scheduled maintenance is considered a normal owner operating cost and will be charged to you by your dealer. Keeping an accurate maintenance record will help ensure your vehicle is properly maintained.

➔ P. 65

Make sure whoever performs the scheduled maintenance completes the maintenance record. Retain all service documents. If you sell your vehicle, these service documents should be transferred with the vehicle to the new owner.

Items		Frequency*1								Regular Replace	Refer to page
		× 1,000 mi	0.6	4	8	12	16	20	24		
		× 1,000 km	1.0	6.4	12.8	19.2	25.6	32.0	38.4		
Emission-Related Items	Fuel Line	⚡		I	I	I	I	I	I		-
	Throttle Operation	⚡		I	I	I	I	I	I		94
	Air Cleaner*2					R			R		-
	Crankcase Breather*3			C	C	C	C	C	C		74
	Spark Plug			I	R	I	R	I	R		-
	Valve Clearance	⚡		I	I	I	I	I	I		-
	Engine Oil		R	R	R	R	R	R	R	1 Year	83
	Engine Oil Strainer Screen				C		C		C		-
	Engine Idle Speed	⚡		I	I	I	I	I	I		-
	Radiator Coolant*5				I		I		I	3 Years	85
	Cooling System	⚡			I		I		I		-
	Evaporative Emission Control System*4	⚡					I		I		-









Maintenance Level

- ⚡ : Intermediate. We recommend service by your dealer, unless you have the necessary tools and are mechanically skilled.
Procedures are provided in an official Honda Service Manual (📖 P. 135).
- ⚡ : Technical. In the interest of safety, have your vehicle serviced by your dealer.

Maintenance Legend

- I : Inspect (clean, adjust, lubricate, or replace, if necessary)
R : Replace
C : Clean

Maintenance Schedule

Items		Frequency*1									
		× 1,000 mi	0.6	4	8	12	16	20	24	Regular Replace	Refer to page
		× 1,000 km	1.0	6.4	12.8	19.2	25.6	32.0	38.4		
Non-Emission-Related Items	Drive Belt 				I		R		I		-
	Final Drive Oil *5 									2 Years	-
	Brake Fluid*5			I	I	I	I	I	I	2 Years	87
	Brake Shoes/Pads Wear			I	I	I	I	I	I		88, 92
	Brake System			I	I	I	I	I	I		87
	Brake Lock Operation 			I	I	I	I	I	I		45
	Headlight Aim			I	I	I	I	I	I		-
	Clutch Shoes Wear 				I				I		-
	Side Stand			I	I	I	I	I	I		93
	Suspension 			I	I	I	I	I	I		-
	Nuts, Bolts, Fasteners 				I				I		-
	Wheels/Tires 			I	I	I	I	I	I		74
	Steering Head Bearings 				I				I		-

Notes:

- *1: At higher odometer reading, repeat at the frequency interval established here.
- *2: Service more frequently when riding in unusually wet or dusty areas.
- *3: Service more frequently when riding in rain or at full throttle.
- *4: 50 STATE (meets California).
- *5: Replacement requires mechanical skill.

Maintenance Record

Distance	Odometer	Date	Performed By:	Notes
600 miles (1,000 km)				
4,000 miles (6,400 km)				
8,000 miles (12,800 km)				
12,000 miles (19,200 km)				
16,000 miles (25,600 km)				
20,000 miles (32,000 km)				
24,000 miles (38,400 km)				
28,000 miles (44,800 km)				
32,000 miles (51,200 km)				
36,000 miles (57,600 km)				
40,000 miles (64,000 km)				
44,000 miles (70,400 km)				
48,000 miles (76,800 km)				
52,000 miles (83,200 km)				
56,000 miles (89,600 km)				
60,000 miles (96,000 km)				
64,000 miles (102,400 km)				
68,000 miles (108,800 km)				

Pre-ride Inspection

To ensure safety, it is your responsibility to perform a pre-ride inspection and make sure that any problem you find is corrected. A pre-ride inspection is a must, not only for safety, but because having a breakdown, or even a flat tire, can be a major inconvenience.

Check the following items before you get on your vehicle:

- Tire tread wear and air pressures are within limits. ➤ P. 74
- Lights, horn, and turn signals operate normally.

Check the following items if you are carrying a passenger or cargo:

- Combined weight is within load limits. ➤ P. 142
- Cargo is secured properly.

Check the following items after you get on your vehicle:

- Throttle action moves smoothly without binding. ➤ P. 94
- Brake levers operate normally.
- Check the fuel level and refuel when needed. ➤ P. 13, ➤ P. 52
- Engine stop switch functions properly. ➤ P. 32

Check the following items at regular intervals:

- Oil level is between the upper and lower level marks. ➤ P. 83
- Brake fluid level is above the LOWER level mark. ➤ P. 87
- Engine coolant level is between the UPPER and LOWER level marks. ➤ P. 85
- Side stand functions properly. ➤ P. 93
- Rear brake lock works properly. ➤ P. 45

Periodic Checks

You should also perform other periodic maintenance checks at least once a month regardless of how often you ride, or more often if you ride frequently.

Also, check the odometer reading against the Maintenance Schedule and perform all maintenance that is due. ➤ P. 62

Tires and wheels	Check the air pressure (➤ P. 74), examine tread for wear and damage (➤ P. 74), and check the wheels for damage.
Fluid levels	Check the engine oil level (➤ P. 83), engine coolant level (➤ P. 85), and brake fluid level (➤ P. 87).
Lights	Check that the headlight, accessory lamps, brake light, taillight, turn signals and license plate light are working properly.
Controls	Check the freeplay of the rear brake lever (➤ P. 89), throttle grip (➤ P. 94) and rear brake lock (➤ P. 45) operate properly.
Fuses	Check that you have a full supply of spare fuses.
Nuts & bolts	Check the major nuts and bolts, and tighten as needed.

Replacing Parts

Always use Honda Genuine Parts or their equivalents to ensure reliability and safety. When ordering colored components, specify the model name, color, and code mentioned on the color label.

The color label is attached to the center compartment.  P. 55

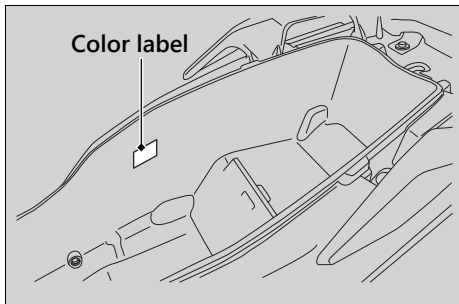

WARNING

Installing non-Honda parts may make your vehicle unsafe and cause a crash in which you can be seriously hurt or killed.

Always use Honda Genuine Parts or equivalents that have been designed and approved for your vehicle.

Battery

Your vehicle has a maintenance-free type battery. You do not have to check the battery electrolyte level or add distilled water. Clean the battery terminals if they become dirty or corroded.

Do not remove the battery cap seals. There is no need to remove the cap when charging.

NOTICE

An improperly disposed of battery can be harmful to the environment and human health. Always confirm local regulations for proper battery disposal instruction.

What to do in an emergency

If any of the following occur, immediately see your doctor.

- Electrolyte splashes into your eyes:
 - ▶ Wash your eyes repeatedly with cool water for at least 15 minutes. Using water under pressure can damage your eyes.

- Electrolyte splashes onto your skin:
 - ▶ Remove affected clothing and wash your skin thoroughly using water.
- Electrolyte splashes into your mouth:
 - ▶ Rinse mouth thoroughly with water, and do not swallow.

WARNING

The battery gives off explosive hydrogen gas during normal operation.

A spark or flame can cause the battery to explode with enough force to kill or seriously hurt you.

Wear protective clothing and a face shield, or have a skilled mechanic do the battery servicing.

WARNING: Battery posts, terminals, and related accessories contain lead and lead compounds.

Wash your hands after handling.

| Cleaning the Battery Terminals

1. Remove the battery. ➤ P. 79
2. If the terminals are starting to corrode and are coated with a white substance, wash with warm water and wipe clean.
3. If the terminals are heavily corroded, clean and polish the terminals with a wire brush or sandpaper. Wear safety glasses.

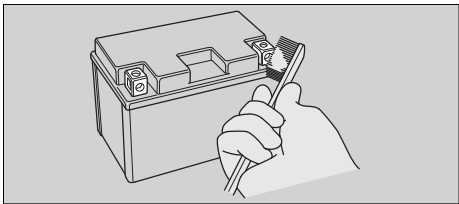

4. After cleaning, reinstall the battery.

The battery has a limited life span. Consult your dealer about when you should replace the battery. Always replace the battery with another maintenance-free battery of the same type.

| Charging

If you use electrical accessories that drain the battery or you do not ride frequently, we recommend that you charge the battery every 30 days using a charger designed specifically for your Honda, which can be purchased from your dealer. Read the information that came with your battery charger and follow the instructions on the battery. Avoid using an automobile-type battery charger, as these can overheat a motorcycle battery and cause permanent damage.

Make sure the ignition switch is in the OFF position before charging the battery.

NOTICE

Improper charging can damage the battery. If you can't charge the battery or it appears unable to hold a charge, contact your dealer.

NOTICE

Jump starting using an automobile battery can damage your vehicle's electrical system and is not recommended. Bump starting is also not recommended.

NOTICE

Installing non-Honda electrical accessories can overload the electrical system, discharging the battery and possibly damaging the system.

Fuses

Fuses protect the electrical circuits on your vehicle. If something electrical on your vehicle stops working, check for and replace any blown fuses. ➤ P. 114

Inspecting and Replacing Fuses

Turn the ignition switch to the OFF position to remove and inspect fuses. If a fuse is blown, replace with a fuse of the same rating. For fuse ratings, see "Specifications." ➤ P. 144

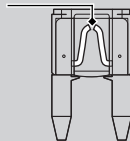
Blown fuse**NOTICE**

Replacing a fuse with one that has a higher rating greatly increases the chance of damage to the electrical system.

Maintenance Fundamentals

If a fuse fails repeatedly, you likely have an electrical fault. Have your vehicle inspected by your dealer.

Engine Oil

Engine oil consumption varies and oil quality deteriorates according to riding conditions and time elapsed.

Check the engine oil level regularly, and add the recommended engine oil if necessary. Dirty oil or old oil should be changed as soon as possible.

Selecting the Engine Oil

For recommended engine oil, see "Specifications." P. 143

If you use non-Honda engine oil, check the label to make sure that the oil satisfies all of the following standards:

- JASO T 903 standard*1: MB
- SAE standard*2: 10W-30
- API classification*3: SG or higher

*1. The JASO T 903 standard is an index for engine oils for 4-stroke motorcycle engines. There are two classes: MA and MB. For example, the following label shows the MB classification.

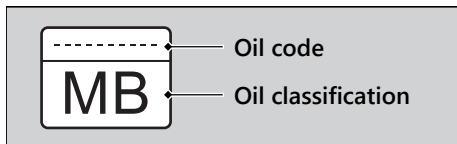

*2. The SAE standard grades oils by their viscosity.

*3. The API classification specifies the quality and performance rating of engine oils. Use SG or higher oils, excluding oils marked as "Energy Conserving" or "Resource Conserving" on the circular API service symbol.

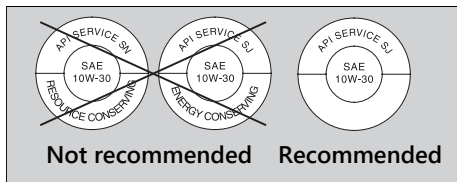

Brake Fluid

Do not add or replace brake fluid, except in an emergency. Use only fresh brake fluid from a sealed container. If you do add fluid, have the brake system serviced by your dealer as soon as possible.

NOTICE

Brake fluid can damage plastic and painted surfaces.
Wipe up spills immediately and wash thoroughly.

Recommended brake fluid:

Honda DOT 3 or DOT 4 Brake Fluid or equivalent

Recommended Coolant

Pro Honda HP Coolant is a pre-mixed solution of antifreeze and distilled water.

Concentration:

50% antifreeze and 50% distilled water

A concentration of antifreeze below 40% will not provide proper corrosion and cold temperature protection.
A concentration of up to 60% will provide better protection in colder climates.

NOTICE

Using coolant not specified for aluminum engines or tap/mineral water can cause corrosion.

Crankcase Breathers

Service more frequently when riding in rain, at full throttle, or after the vehicle is washed or overturned. Service if the deposit level can be seen in the transparent section of the drain tube.

If the drain tube overflows, the air filter may become contaminated with engine oil causing poor engine performance.

Tires (Inspecting/Replacing)

Checking the Air Pressure

Visually inspect your tires and use an air pressure gauge to measure the air pressure at least once a month or any time you think the tires look low. Always check air pressure when your tires are cold.

Inspecting for Damage

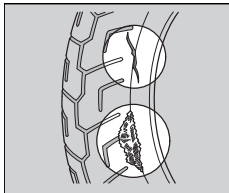

Inspect the tires for cuts, slits, or cracks that exposes fabric or cords, or nails or other foreign objects embedded in the side of the tire or the tread.

Also inspect for any unusual bumps or bulges in the side walls of the tires.

Inspecting for Abnormal Wear

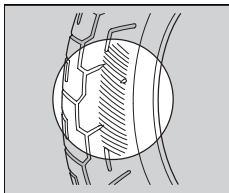

Inspect the tires for signs of abnormal wear on the contact surface.

Inspecting Tread Depth

Inspect the tread wear indicators. If they become visible, replace the tires immediately. For safe riding, you should replace the tires when the minimum tread depth is reached.

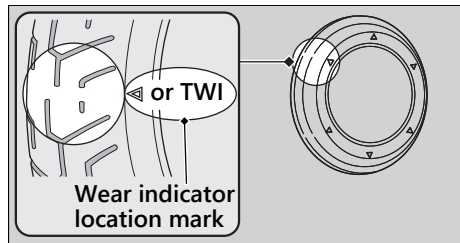

⚠ WARNING

Riding on tires that are excessively worn or improperly inflated can cause a crash in which you can be seriously hurt or killed.

Follow all instructions in this owner's manual regarding tire inflation and maintenance.

Maintenance Fundamentals

Have your tires replaced by your dealer. For recommended tires, air pressure and minimum tread depth, see "Specifications."

➔ P. 143

Follow these guidelines whenever you replace tires.

- Use the recommended tires or equivalents of the same size, construction, speed rating, and load range.
- Do not install a tube inside a tubeless tire on this vehicle. Excessive heat build-up can cause the tube to burst.
- Use only tubeless tires on this vehicle. The rims are designed for tubeless tires, and during hard acceleration or braking, a tube-type tire could slip on the rim and cause the tire to rapidly deflate.

WARNING

Installing improper tires on your vehicle can adversely affect handling and stability, and can cause a crash in which you can be seriously hurt or killed.

Always use the size and type of tires recommended in this owner's manual.

Tire Service Life

The service life of your tires is dependent on many factors, including, but not limited to, riding habits, road conditions, vehicle loading, tire air pressure, maintenance history, speed, and environmental conditions (even when the tires are not in use).

In addition to your regular inspections and maintenance, it is recommended that you have annual inspections performed once the tires reach 5 years old. It is also recommended that all tires be removed from service after 10 years from the date of manufacture, regardless of their condition or state of wear.

The last four digits of the TIN (tire identification number) indicate the date of manufacture.

Tire Identification Number (TIN)

The tire identification number (TIN) is a group of numbers and letters located on the sidewall of the tire.



DOT XXXX XXXX 22 09

DOT: This indicates that the tire meets all requirements of the U.S. Department of Transportation.

- ① XXXX: Factory code
- ② XXXX: Tire type code
- ③ 22 09: Date of manufacture (week & year).
Example: week 22 in year 09.

Tire Labeling Example



The tool bag and helmet set wire are stored underside of the seat. ➤ P. 57

- Helmet set wire

Battery

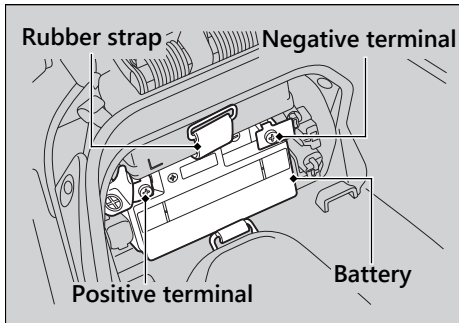

Removal

Make sure the ignition switch is in the OFF position.

1. Remove the battery cover. ➤ P. 80
2. Unhook the rubber strap.
3. Disconnect the negative \ominus terminal from the battery.

4. Disconnect the positive \oplus terminal from the battery.
5. Remove the battery taking care not to drop the terminal nuts.

Installation

Install the parts in the reverse order of removal.

Always connect the positive \oplus terminal first. Make sure that bolts and nuts are tight.

Make sure the clock information is correct after the battery is reconnected. ➤ P. 26
To activate the system, turn the ignition switch to the ON position once.

For proper handling of the battery, see "Maintenance Fundamentals." ➤ P. 69
"Battery Goes Dead." ➤ P. 113

Battery Cover

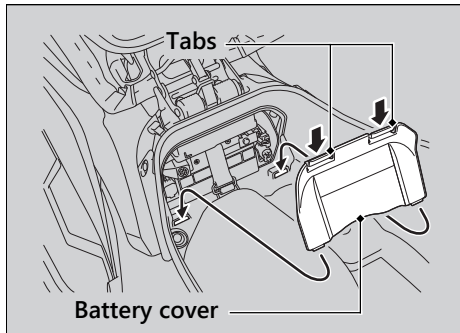

Removal

1. Open the seat. ► P. 55
2. Press the tabs and remove the battery cover.

Installation

Install the parts in the reverse order of removal.

Clip

Removal

1. Press down on the center pin to release the lock.
2. Pull the clip out of the hole.

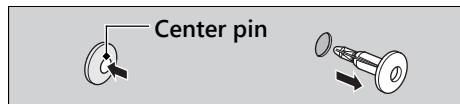

Installation

1. Push the bottom of the center pin.



2. Insert the clip into the hole.
3. Press down on the center pin to lock the clip.

Front Lid

Removal

Pull out the front lid backward while pushing the side of the front lid.

Installation

Install the part in the reverse order of removal.

Make sure that all tabs are installed securely in position.

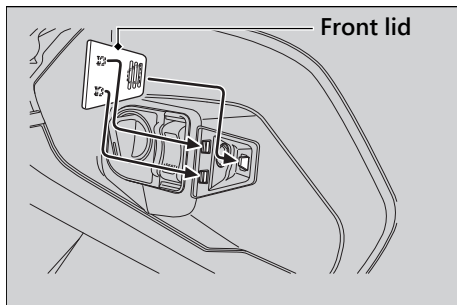
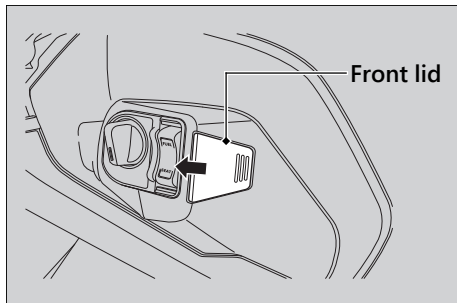

Checking the Engine Oil

1. If the engine is cold, idle the engine for 3 to 5 minutes.
2. Turn the ignition switch to the OFF position and wait for 2 to 3 minutes.
3. Place your vehicle on its center stand on a firm, level surface.
4. Remove the oil fill cap/dipstick and wipe it clean.
5. Insert the oil fill cap/dipstick until it seats, but don't screw it in.
6. Check that the oil level is between the upper level and lower level marks on the oil fill cap/dipstick.
7. Securely install the oil fill cap/dipstick.

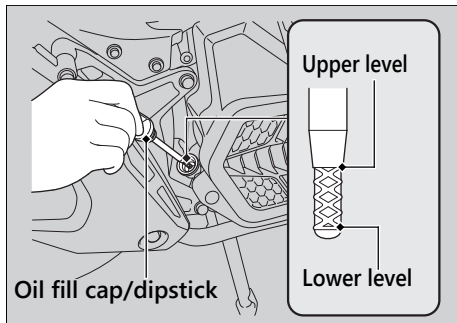

Adding Engine Oil

If the engine oil is below or near the lower level mark, add the recommended engine oil.

► P. 72, ► P. 143

1. Remove the oil fill cap/dipstick. Add the recommended oil until it reaches the upper level mark.
 - Place your vehicle on its center stand on a firm, level surface when checking the oil level.
 - Do not overfill above the upper level mark.
 - Make sure no foreign objects enter the oil filler opening.
 - Wipe up any spills immediately.
2. Securely reinstall the oil fill cap/dipstick.

NOTICE

Overfilling with oil or operating with insufficient oil can cause damage to your engine. Do not mix different brands and grades of oil.

For the recommended oil and oil selection guidelines, see "Maintenance Fundamentals."

► P. 72

Checking the Coolant

Check the coolant level in the reserve tank while the engine is cold.

1. Place your vehicle on its center stand on a firm, level surface.
2. Check that the coolant level is between the UPPER level and LOWER level marks on the reserve tank.

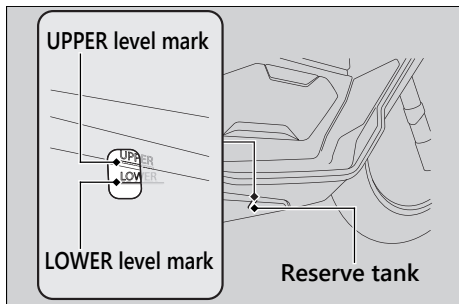

If the coolant level is dropping noticeably or the reserve tank is empty, you likely have a serious leak. Have your vehicle inspected by your dealer.

Adding Coolant

If the coolant level is below the LOWER level mark, add the recommended coolant (▶ P. 73) until the level reaches the UPPER level mark.

Add fluid only from the reserve tank cap and do not remove the radiator cap.

1. Pull the floor mat off.
2. Remove the reserve tank lid by inserting a flat head screwdriver covered with a protective cloth into the slit on the right side floor.

Coolant ► Adding Coolant

3. Remove the reserve tank cap and add fluid while monitoring the coolant level.
 - Do not overfill above the UPPER level mark.
 - Make sure no foreign objects enter the reserve tank opening.
4. Securely reinstall the reserve tank cap.
5. Install the reserve tank lid and floor mat.

⚠ WARNING

Removing the radiator cap while the engine is hot can cause the coolant to spray out, potentially scalding you.

Always let the engine and radiator cool down before removing the radiator cap.

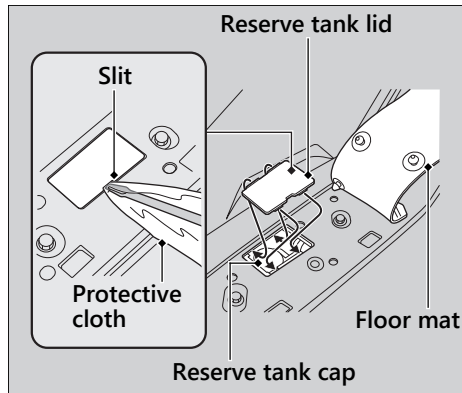

Checking the Front Brake Fluid

1. Place your vehicle in an upright position on a firm, level surface.
2. Check that the brake fluid reservoir is horizontal and that the fluid level is above the LOWER level mark.

If the brake fluid level in the reservoir is below the LOWER level mark or the brake lever freeplay becomes excessive, inspect the brake pads for wear.

If the brake pads are not worn, you most likely have a leak. Have your vehicle inspected by your dealer.

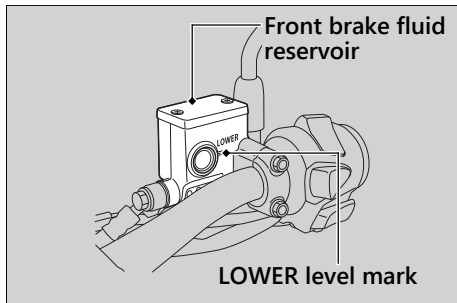

Inspecting the Front Brake Pads

Check the condition of the brake pad wear indicators.

The pads need to be replaced if a brake pad is worn to the indicator.

Inspect the brake pads from in front of the brake caliper.

If necessary have the pads replaced by your dealer.

Always replace both left and right brake pads at the same time.

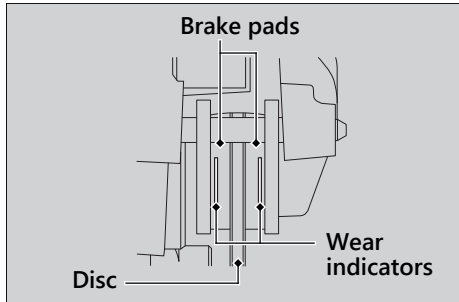

Inspecting the Rear Brake Lever Freeplay

1. Place the vehicle on its center stand.
2. Measure the distance the rear brake lever moves before the brake takes hold.

Freeplay at the tip of the brake lever:

3/8 - 13/16 in (10 - 20 mm)

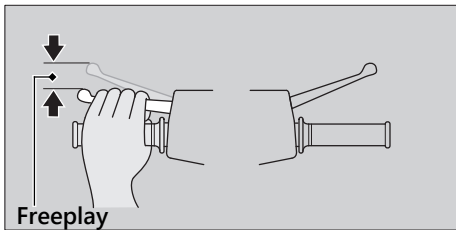

Check the brake cable for kinks or signs of wear. If necessary have it replaced by your dealer.

Lubricate the brake cable with a commercially available cable lubricant to prevent premature wear and corrosion. Make sure the brake arm, spring and fastener are in good condition.

Adjusting the Rear Brake Lever Freeplay

Adjust the freeplay of the brake lever with the front wheel pointed straight ahead. Make sure the cut-out on the adjusting nut is seated on the brake arm pin when adjusting the freeplay.

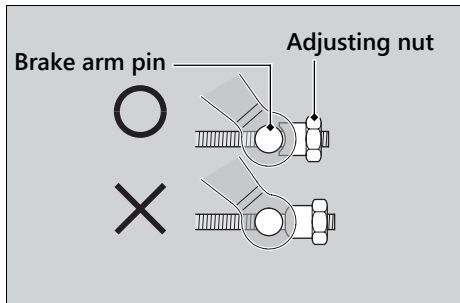

If proper adjustment cannot be obtained by this method, see your dealer.

1. Adjust by turning the rear brake adjusting nut a half-turn at a time.

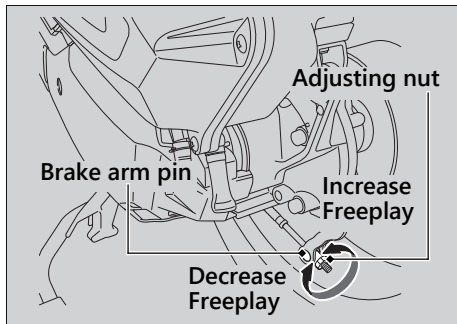

2. Apply the brake several times and check for free wheel rotation after the brake lever is released.

3. Push the brake arm to confirm that there is a gap between the rear brake adjusting nut and brake arm pin.

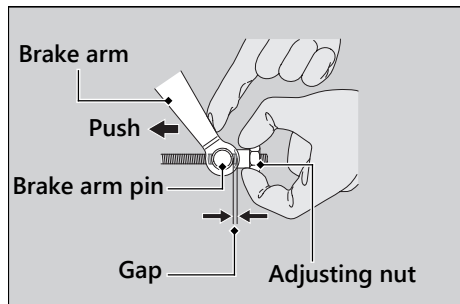

After adjustment, confirm the freeplay of the brake lever.

Make sure the brake arm, spring and fastener are in good condition.

NOTICE

Do not turn the adjuster beyond its natural limits.

Inspecting the Rear Brake Shoe Wear

The rear brake is equipped with a brake wear indicator.

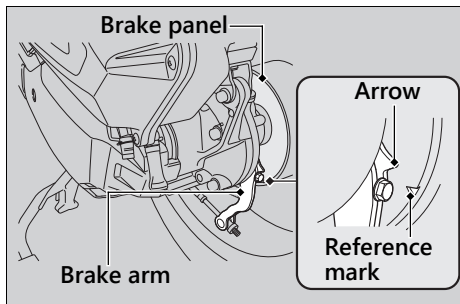

When the brake is applied, an arrow attached to the brake arm moves toward a reference mark on the brake panel. If the arrow aligns with the reference mark on full application of the brake, the brake shoes must be replaced. See your dealer for this service.

When the brake service is necessary, see your dealer. Use only Honda Genuine Parts or its equivalent.

Checking the Side Stand

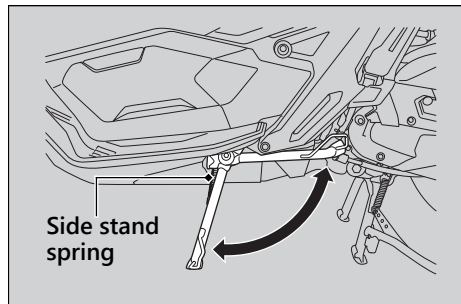

1. Place your vehicle on its center stand on a firm, level surface.
2. Check that the side stand operates smoothly. If the side stand is stiff or squeaky, clean the pivot area and lubricate the pivot bolt with clean grease.

3. Check the spring for damage or loss of tension.
4. Sit on the vehicle and raise the side stand.
5. Start the engine.
6. Lower the side stand all the way. The engine should stop as you lower the side stand. If the engine doesn't stop, have your vehicle inspected by your dealer.

Checking the Throttle

With the engine off, check that the throttle rotates smoothly from fully closed to fully open in all steering positions and throttle freeplay is correct. If the throttle does not move smoothly, close automatically, or if the cable is damaged, have the vehicle inspected by your dealer.

Freeplay at the throttle grip flange:

1/16 - 1/4 in (2 - 6 mm)

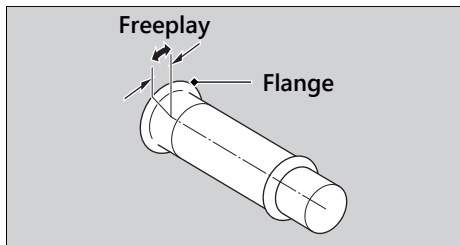

Adjusting the Windscreen Height

The windscreen can be adjusted to 2 positions.

▶ Do not adjust the windscreen while riding.

Pull the windscreen adjusting knobs and move the windscreen up or down.

▶ Make sure the windscreen is locked securely by slightly moving the windscreen up or down.

If the windscreen does not move smoothly, have your vehicle inspected by your dealer.

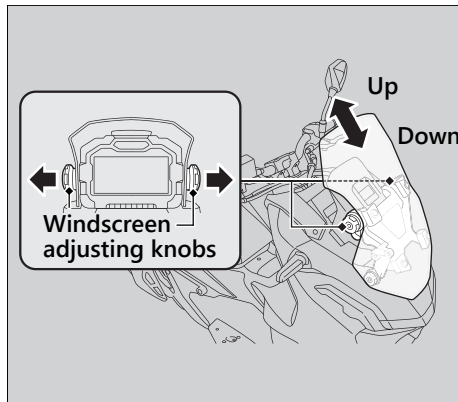

Replacing the Honda SMART Key Battery

If the Honda SMART Key indicator flashes 5 times when the ignition switch is turned ON, or the operating range becomes unstable, replace the battery as soon as possible.

We recommend to see your dealer for this service.

Battery type: CR2032

1. Remove the upper case by inserting a coin or a flat head screwdriver covered with a protective cloth into the slit.
 - ▶ Wrap a coin or a screwdriver with a protective cloth to prevent scratching the Honda SMART Key.
 - ▶ Do not touch the circuit or terminal. This may cause problems.
 - ▶ Be careful to avoid scratching the waterproof covering or allowing dust to enter.
 - ▶ Do not forcibly dismantle the Honda SMART Key body.

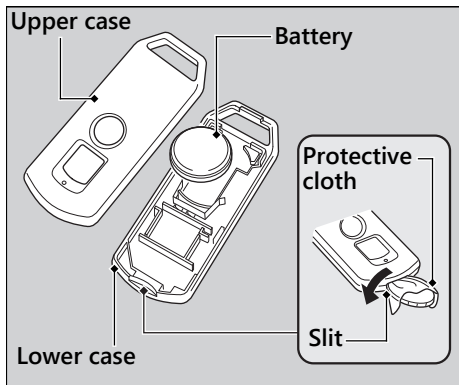

2. Replace the old battery with a new battery with the negative \ominus side facing up.
3. Snap the two halves of the remote transmitter back together.
 - Make sure that upper and lower cases are set in the right position.

⚠ WARNING

Chemical Burn Hazard: do not swallow battery.

If swallowed, the battery can cause severe internal burns and even death.

- Keep battery away from children and battery compartment securely closed.
- If the battery compartment does not close securely, stop using the product and keep it away from children.
- Immediately seek medical attention if a child may have swallowed battery.

Troubleshooting

Engine Will Not Start	P. 99	Unlock the Ignition Switch in an Emergency	P. 109
Overheating (High coolant temperature indicator is on)	P. 100	Tire Puncture	P. 112
Warning Indicators On or Flashing	P. 101	Electrical Trouble	P. 113
PGM-FI (Programmed Fuel Injection)		Battery Goes Dead	P. 113
Malfunction Indicator Lamp (MIL).....	P. 101	Burned-out Light Bulb	P. 113
ABS (Anti-lock Brake System) Indicator	P. 102	Blown Fuse	P. 114
Honda SMART Key Indicator	P. 103	Unstable Engine Operation Occurs Intermittently	P. 115
Other Warning Indications	P. 105		
Fuel Gauge Failure Indication.....	P. 105		
When the Honda SMART Key System Does Not Operate Properly	P. 106		
Unlock the Seat in an Emergency	P. 108		

Starter Motor Operates But Engine Does Not Start

Check the following items:

- Check the correct engine starting sequence. ➤ P. 46
- Check that there is gasoline in the fuel tank.
- Check if the PGM-FI malfunction indicator lamp (MIL) is on.
 - ▶ If the indicator lamp is on, contact your dealer as soon as possible.

Starter Motor Does Not Operate

Check the following items:

- Check the correct engine starting sequence. ➤ P. 46
- Make sure engine stop switch is in the  (Run) position. ➤ P. 32
- Check for a blown fuse. ➤ P. 114
- Check for a loose battery connection (➤ P. 79) or battery terminal corrosion (➤ P. 69).
- Check the condition of the battery.
 - P. 113

If the problem continues, have your vehicle inspected by your dealer.

Overheating (High coolant temperature indicator is on)

The engine is overheating when the following occurs:

- High coolant temperature indicator comes on.
- Acceleration becomes sluggish.

If this occurs, pull safely to the side of the road and perform the following procedure. Extended fast idling may cause the high coolant temperature indicator to come on.

NOTICE

Continuing to ride with an overheated engine can cause serious damage to the engine.

1. Stop the engine using the ignition switch.
2. Allow the engine to cool with the ignition switch in the OFF position.
3. After the engine has cooled, inspect the radiator hose and check if there is a leak.
➔ P. 85
If there is a leak:
Do not start the engine. Transport your vehicle to your dealer.
4. Check the coolant level in the reserve tank. ➔ P. 85
▶ Add coolant as necessary.
5. If 1-4 check normal, you may continue riding, but closely monitor the high coolant temperature indicator.

PGM-FI (Programmed Fuel Injection) Malfunction Indicator Lamp (MIL)

If the indicator comes on while riding, you may have a serious problem with the PGM-FI system. Reduce speed and have your vehicle inspected by your dealer as soon as possible.

ABS (Anti-lock Brake System) Indicator

If the indicator operates in one of the following ways, you may have a serious problem with the ABS. Reduce your speed and have your vehicle inspected by your dealer as soon as possible.

- Indicator comes on or starts flashing while riding.
- Indicator does not come on when the ignition switch is in the ON position.
- Indicator does not go off at speeds above 6 mph (10 km/h).

If the ABS indicator stays on, your brakes will continue to work as a conventional system, but without the anti-locking function.

The ABS indicator may flash if you turn the rear wheel while the rear wheel is lifted off the ground. In this case, turn the ignition switch to the OFF position, and then to the ON position again. The ABS indicator will go off after your speed reaches 19 mph (30 km/h).

Honda SMART Key Indicator

When the Honda SMART Key indicator flashes 5 times

Replacing the Honda SMART Key Battery  P. 96

When the Honda SMART Key indicator is flashing while the ignition switch is in the ON position

The Honda SMART Key indicator flashes when communication between your vehicle and Honda SMART Key stops after turning the ignition switch to the ON position.

It is probably caused by the following:

- Strong radio waves or noise are affecting the system
- Unable to authenticate between Honda SMART Key and vehicle when pressing the start button or ignition switch.

- You lose the Honda SMART Key while riding

However, this does not affect the operation of your vehicle until the ignition switch is locked.

If you turn the ignition switch to the SEAT FUEL, OFF or LOCK position while the Honda SMART Key indicator is flashing, the ignition switch ring, the Honda SMART Key indicator will come on, and the buzzer will ring for about 20 seconds, automatically go off, and then the ignition switch will lock.

- Turn signal lights blink at the beginning and end of this function.

Also, to stop this flashing and ringing, press and hold the ignition switch for more than 2 seconds. After the flashing and ringing stop, the ignition switch is locked.

Warning Indicators On or Flashing ► Honda SMART Key Indicator

If you do not have the Honda SMART Key, the ignition switch can be unlocked in another way.  P. 109

Fuel Gauge Failure Indication

If the fuel system has an error, the fuel gauge indicators will be displayed as shown in the illustrations.

If this occurs, see your dealer as soon as possible.

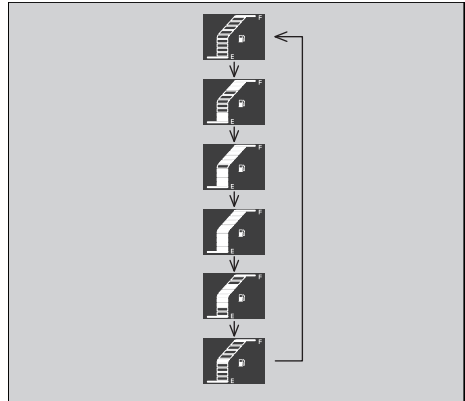
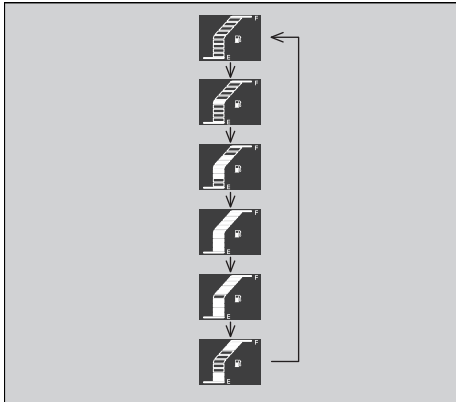

When the Honda SMART Key System Does Not Operate Properly

When the Honda SMART Key system does not work properly, perform the following.

- Check that the Honda SMART Key system is activated.

Lightly push the ON/OFF button on the Honda SMART Key.

If the LED of the Honda SMART Key is red, switch the Honda SMART Key system to activation. ▣ P. 36

If the LED of the Honda SMART Key does not respond, replace the battery of the Honda SMART Key.

- Check that there is no communication failure in the Honda SMART Key system. The Honda SMART Key system uses low-intensity radio waves. The Honda SMART Key system may not work properly in the following conditions:
 - ▶ When there are facilities nearby that generate strong radio waves or noise such as TV towers, power stations, radio stations, or airports.
 - ▶ When you carry the Honda SMART Key with a laptop or wireless communication device such as a radio or mobile phone.
 - ▶ When the Honda SMART Key comes into contact with or is covered by metal objects.

When the Honda SMART Key System Does Not Operate Properly

- Check that a registered Honda SMART Key is used.
Use a registered Honda SMART Key. The Honda SMART Key system cannot be activated without a registered Honda SMART Key.
- Make sure that you do not use a broken Honda SMART Key.
If you use a broken Honda SMART Key, the Honda SMART Key system cannot be activated. Bring the emergency key and ID tag to your dealer.

- Check the battery condition and battery lead in your vehicle.
Check the battery and battery terminals. If the battery is weak, contact your dealer.

If the Honda SMART Key system cannot be activated due to other causes, contact your dealer.

Unlock the Seat in an Emergency

The seat lock can be unlocked by using the emergency key.

Open

1. Remove the front lid. ➤ P. 82
2. Align the projection of the emergency key with the slot of the emergency seat opener, and turn the emergency key counterclockwise.
3. Open the seat and turn the emergency key clockwise

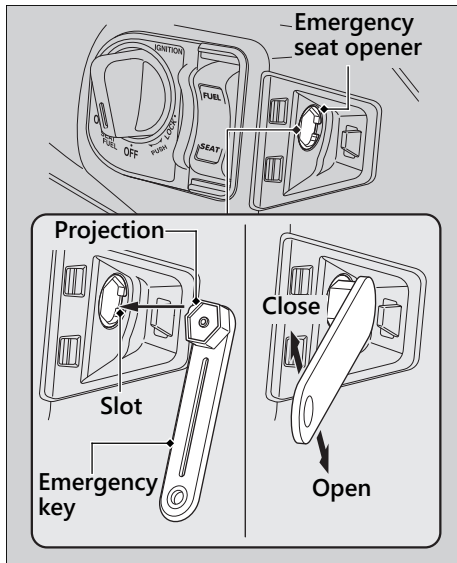

Close

1. Close and push down on the rear of the seat until it locks. Make sure that the seat is locked securely by pulling it up lightly. If the seat is not locked, turn the emergency key clockwise to lock the seat catch.
2. Install the front lid.



Unlock the Ignition Switch in an Emergency

Set up to ID number input mode

1. Use the emergency key to open the seat.  P. 108
2. Remove the battery cover.  P. 80
3. Pull out the EM mode connector.
4. Remove the blue dummy coupler by releasing the tab of the EM mode connector while lifting the hook of the blue dummy coupler.
5. Check the ID number on the ID tag.
6. Connect the EM mode coupler provided in the tool kit to the EM mode connector.

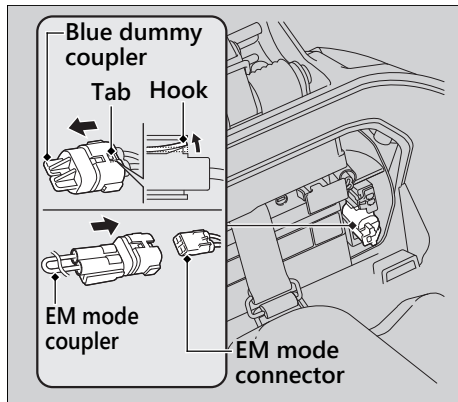

Unlock the Ignition Switch in an Emergency

ID number input

You can input your ID number by pressing the ignition switch when the ignition switch is OFF, LOCK and SEAT FUEL position. Input the ID number on the ID tag in order from the left in turn by pressing the ignition switch.

The ID number is authenticated according to the number of times the ignition switch is pushed.

Push the ignition switch the desired number of times within 5 seconds when the ignition switch ring comes on. After 5 seconds, the ignition switch ring goes off and comes on again. This means that the inputted number is fixed, and you can input the next number.

- ▶ If the ignition switch ring does not come on in blue, the battery may be low. Contact your dealer.

Example:

- To input "0", wait for 5 seconds without pushing the ignition switch when the ignition switch ring comes on.
- To input "1", push the ignition switch once within 5 seconds when the ignition switch ring comes on.

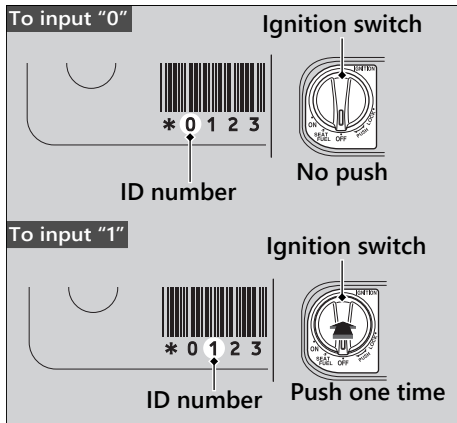

ID number input success

After the last ID number is inputted, through the ignition switch ring and Honda SMART Key Indicator will flash every 2 seconds until the EM mode coupler is removed.

Be sure to remove the EM mode coupler and return the blue dummy coupler. Buzzer rings 2 times when the EM mode coupler was removed. The ignition switch is then unlocked. Reinstall the parts in reverse order of removal and turn the ignition switch to the ON position within 6 minutes. You can start the engine.

To lock the ignition switch, turn the ignition switch to the SEAT FUEL, OFF, or LOCK position, and press and hold the ignition switch for 2 seconds. Buzzer rings 1 time. The ignition switch also locks automatically when the ignition switch has been in the SEAT FUEL, OFF, or LOCK position for about 6 minutes after the ID number is successfully inputted.

When the ignition switch is locked, the ignition switch ring goes off.

To unlock the ignition switch again, repeat the procedure for unlocking the ignition switch.

ID number input failure

After the last ID number is inputted, the ignition switch ring and Honda SMART Key Indicator will flash every second until the EM mode coupler is removed, and the ignition switch cannot be unlocked.

Pull out the EM mode coupler and reconnect it to the EM mode connector. Follow the procedure again. ➔ P. 110

ID number input cancel

Pull out the EM mode coupler from the EM mode connector.

Also, if you make a mistake while inputting the ID number, remove the EM mode coupler from the EM mode connector, connect it to the EM mode connector again, and then re-input the ID number from the beginning.

- Store the removed EM mode coupler in the tool kit at all times.

Repairing a puncture or removing a wheel requires special tools and technical expertise. We recommend you have this type of service performed by your dealer.

After an emergency repair, always have the tire inspected/replaced by your dealer.

Emergency Repair Using a Tire Repair Kit

If your tire has a minor puncture, you can make an emergency repair using a tubeless tire repair kit.

Follow the instructions provided with the emergency tire repair kit.

Riding your vehicle with a temporary tire repair is very risky. Do not exceed 30 mph (50 km/h). Have the tire replaced by your dealer as soon as possible.

⚠️WARNING

Riding your vehicle with a temporary tire repair can be risky. If the temporary repair fails, you can crash and be seriously injured or killed.

If you must ride with a temporary tire repair, ride slowly and carefully and do not exceed 30 mph (50 km/h) until the tire is replaced.

Battery Goes Dead

Charge the battery using a motorcycle battery charger.

Remove the battery from the vehicle before charging.

Do not use an automobile-type battery charger, as these can overheat a motorcycle battery and cause permanent damage. If the battery does not recover after recharging, contact your dealer.

NOTICE

Jump starting using an automobile battery can damage your vehicle's electrical system and is not recommended.

Bump starting is also not recommended.

Burned-out Light Bulb

All light bulbs on the vehicle are LEDs. If there is an LED which is not turned on, see your dealer for servicing.

Blown Fuse

Before handling fuses, see "Inspecting and Replacing Fuses." ► P. 71

Fuse Box Fuses

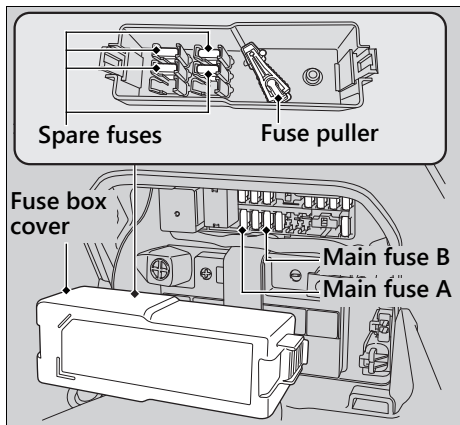

1. Remove the battery cover. ► P. 80
2. Open the fuse box cover.
3. Pull the main fuse and other fuses out one by one with the fuse puller located inside of the fuse box cover. Check for a blown fuse. Always replace a blown fuse with a spare fuse of the same rating.
4. Install the fuse box cover.
5. Install the battery cover.

NOTICE

If a fuse fails repeatedly, you likely have an electrical problem. Have your vehicle inspected by your dealer.

Unstable Engine Operation Occurs Intermittently

If the fuel pump filter is clogged, unstable engine operation will occur intermittently while riding.

Even if this symptom occurs, you can continue to ride your vehicle.

If unstable engine operation occurs even if sufficient fuel is available, have your vehicle inspected by your dealer as soon as possible.

Information

Keys.....	P. 117
Instruments, Controls, & Other Features...	P. 120
Caring for Your Vehicle.....	P. 121
Storing Your Vehicle.....	P. 125
Transporting Your Vehicle	P. 126
You & the Environment	P. 127
Vehicle Identification Number.....	P. 128
Emission Control Systems	P. 129
Catalytic Converter	P. 133
Oxygenated Fuels.....	P. 134
Authorized Manuals	P. 135
Warranty Coverage and Service	P. 136
Honda Contacts.....	P. 139
Reporting Safety Defects	P. 140

Keys

Emergency Key

The emergency key is used for an emergency.

- To unlock the seat. ➤ P. 108
- To unlock the ignition switch. ➤ P. 109

Do not store the emergency key in any compartment.

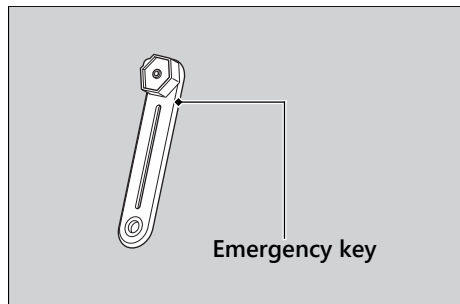

Honda SMART Key

Carrying the Honda SMART Key allows you to perform the following operations:

- Starting the engine
- Locking or unlocking the ignition switch
- Releasing the seat lock
- Opening the fuel lid
- Locking or unlocking the steering

The ID number of the Honda SMART Key is on the ID tag. You can also unlock the ignition switch by inputting the ID number.

Always carry both the emergency key and ID tag, but separate from the Honda SMART Key, to avoid losing all of them at the same time.

Also store a copy of your ID number in a safe place other than your vehicle.

The Honda SMART Key contains electronic circuits. If the circuits are damaged, the Honda SMART Key will not allow you to perform any operations.

- Do not drop the Honda SMART Key or set heavy objects on them.
- Protect the Honda SMART Key from direct sunlight, high temperature, and high humidity.
- Do not scratch or puncture.
- Do not store near any magnetized products such as a magnetized key chain.
- Always keep the Honda SMART Key away from electric appliances such as a TV, radio, PC or low-frequency massage device.
- Keep the Honda SMART Key away from liquids. If it gets wet, dry it immediately with a soft cloth.
- Keep the Honda SMART Key away from the vehicle while washing the vehicle.
- Do not burn.
- Do not wash in an ultrasonic cleaner.

- If fuel, wax, or grease adhere to the Honda SMART Key, wipe it off immediately to avoid cracking or warping.
- Do not disassemble the Honda SMART Key other than when changing a battery. Only the cover of the Honda SMART Key can be disassembled. Do not disassemble other parts.
- Do not lose your Honda SMART Key. If you lose it, you will need to register a new Honda SMART Key. See your dealer with your emergency key and ID tag for registration.

The battery in the Honda SMART Key system normally lasts about 2 years.

Do not keep mobile phones or other radio transmitting devices in any compartment. The radio frequency from the devices will interrupt the Honda SMART Key system.

To get an additional Honda SMART Key, take the Honda SMART Key and the vehicle to your dealer.

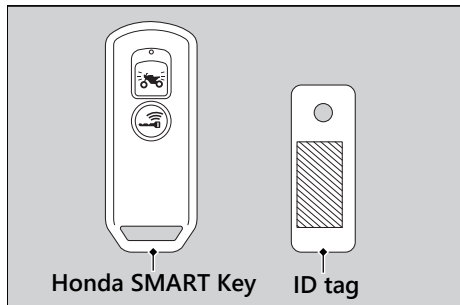

Instruments, Controls, & Other Features

Ignition Switch

Leaving the ignition switch in the ON position with the engine stopped will drain the battery.

Do not turn the ignition switch while riding.

Engine Stop Switch

Do not use the engine stop switch except in an emergency. Doing so when riding will cause the engine to suddenly turn off, making riding unsafe.

If you stop the engine using the engine stop switch, turn the ignition switch to the OFF position. Failing to do so will drain the battery.

Odometer

The display locks at 999,999 when the read-out exceeds 999,999.

Tripmeter

The tripmeters return to 0.0 when each read-out exceeds 9,999.9.

Also average fuel mileage and fuel consumption are reset at the same time.

Document Bag

The owner's manual, registration, and insurance information can be stored in the plastic document bag located underside of the seat.

Caring for Your Vehicle

Frequent cleaning and polishing is important to ensure the life of your Honda. A clean vehicle makes it easier to spot potential problems. In particular, seawater and salts used to prevent ice on roads promote the formation of corrosion. Always wash your vehicle thoroughly after riding on coastal or treated roads.

Washing

Allow the engine, muffler, brakes, and other high-temperature parts to cool before washing.

1. Rinse your vehicle thoroughly using a low pressure garden hose to remove loose dirt.
2. If necessary, use a sponge or a soft towel with mild cleaner to remove road grime.
 - ▶ Clean the windshield, headlight lens, panels, and other plastic components with extra care to avoid scratching them. Avoid directing water into the air cleaner, muffler, and electrical parts.

3. Thoroughly rinse your vehicle with plenty of clean water and dry with a soft, clean cloth.
4. After the vehicle dries, lubricate any moving parts.
 - ▶ Make sure that no lubricant spills onto the brakes or tires. Brake discs, pads, drum or shoes contaminated with oil will suffer greatly reduced braking effectiveness and can lead to a crash.
5. Apply a coat of wax to prevent corrosion.
 - ▶ Avoid products that contain harsh detergents or chemical solvents. These can damage the metal, paint, and plastic on your vehicle. Keep the wax clear of the tires and brakes.
 - ▶ If your vehicle has any matte painted parts, do not apply a coat of wax to the matte painted surface.

Washing Precautions

Follow these guidelines when washing:

- Do not use high-pressure washers:
 - ▶ High-pressure water cleaners can damage moving parts and electrical parts, rendering them inoperable.
 - ▶ Water in the air intake can be drawn into the throttle body and/or enter the air cleaner.
 - Do not direct water at the muffler:
 - ▶ Water in the muffler can prevent starting and causes rust in the muffler.
 - Dry the brakes:
 - ▶ Water adversely affects braking effectiveness. After washing, apply the brakes intermittently at low speed to help dry them.
 - Do not direct water under the seat:
 - ▶ Water in the under seat compartment can damage your documents and other belongings.
-
- Do not direct water at the air cleaner:
 - ▶ Water in the air cleaner can prevent the engine from starting.
 - Do not direct water near the headlight:
 - ▶ The headlight's inside lens may fog temporarily after washing or while riding in the rain. This does not impact the headlight function. However, if you see a large amount of water or ice accumulated inside the lens(es), have your vehicle inspected by your dealer.
 - Do not use wax or polishing compounds on matte painted surface:
 - ▶ Use a soft cloth or sponge, plenty of water, and a mild detergent to clean matte painted surfaces. Dry with a soft clean cloth.

Aluminum Components

Aluminum will corrode from contact with dirt, mud, or road salt. Clean aluminum parts regularly and follow these guidelines to avoid scratches:

- Do not use stiff brushes, steel wool, or cleaners containing abrasives.
- Avoid riding over or scraping against curbs.

Panels

Follow these guidelines to prevent scratches and blemishes:

- Wash gently using a soft sponge and plenty of water.
- To remove stubborn stains, use diluted detergent and rinse thoroughly with plenty of water.
- Avoid getting gasoline, brake fluid, or detergents on the instruments, panels, or headlight.

Windscreen

Using plenty of water, clean the windscreen with a soft cloth or sponge. (Avoid using detergents or any kind of chemical cleaner on the windscreen.) Dry with a soft, clean cloth.

NOTICE

To avoid possible scratching or other damage, use only water and a soft cloth or sponge to clean the windscreen.

For a dirtier windscreen, use a diluted neutral detergent with a sponge and plenty of water. Make sure to wash off all the detergent. (Detergent residue may cause windscreen cracks.)

Replace the windscreen if scratches cannot be removed and they obstruct clear vision.

Take care to keep battery electrolyte, brake fluid, or other chemical solvents off the windscreen and screen garnish. They will damage the plastic.

Exhaust Pipe and Muffler

When the exhaust pipe and muffler are painted, do not use a commercially available abrasive kitchen cleaning compound. Use a neutral detergent to clean the painted surface on the exhaust pipe and muffler. If you are not sure if your exhaust pipe and muffler are painted, contact your dealer.

Storing Your Vehicle

If you store your vehicle outdoors, you should consider using a full-body cover.

If you won't be riding for an extended period, follow these guidelines:

- Wash your vehicle and wax all painted surfaces (except matte painted surfaces). Coat chrome pieces with rust-inhibiting oil.
- Place your vehicle on its center stand and position a block so that both tires are off the ground.
- After rain, remove the body cover and allow the vehicle to dry.
- Remove the battery (➤ P. 79) to prevent discharge. Fully charge the battery and then place it in a shaded, well-ventilated area.
 - ▶ If you leave the battery in place, disconnect the negative ⊖ terminal to prevent discharge.

After removing your vehicle from storage, inspect all maintenance items required by the Maintenance Schedule.

For more information about storage, refer to the *Honda Winter Storage Guide*, available from your dealer.

Transporting Your Vehicle

If your vehicle needs to be transported, it should be carried on a motorcycle trailer or a flatbed truck or trailer that has a loading ramp or lifting platform, and motorcycle tie-down straps. Never try to tow your vehicle with a wheel or wheels on the ground.

NOTICE

Towing your vehicle can cause serious damage to the transmission.

You & the Environment

Owning and riding a vehicle can be enjoyable, but you must do your part to protect the environment.

Choose Sensible Cleaners

Use a biodegradable detergent when you wash your vehicle. Avoid aerosol spray cleaners that contain chlorofluorocarbons (CFCs) which damage the atmosphere's protective ozone layer.

Recycle Wastes

Put oil and other toxic wastes in approved containers and take them to a recycling center. Call your local or state office of public works or environmental services to find a recycling center in your area, and to get instructions on how to dispose of non-recyclable wastes. Do not place used engine oil in the trash, or pour it down a drain or on the ground. Used oil, gasoline, coolant, and cleaning solvents contain poisons that can hurt refuse workers and contaminate drinking water, lakes, rivers, and oceans.

Vehicle Identification Number

The VIN and engine serial number uniquely identify your vehicle and are required in order to register your vehicle. They may also be required when ordering replacement parts. To check the VIN, open the seat. ➤ P. 55 You should record these numbers and keep them in a safe place.

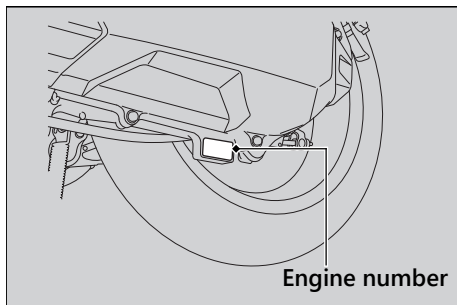
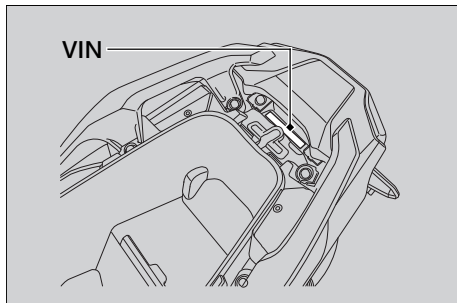
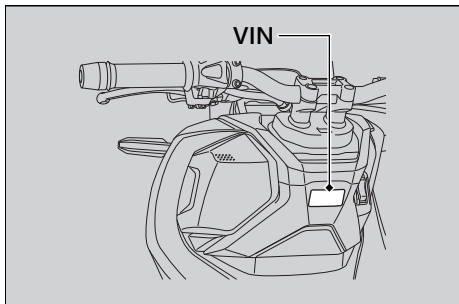

Emission Control Systems

Your vehicle engine emits combustion byproducts, including carbon monoxide (CO), oxides of nitrogen (NO_x), and hydrocarbons (HC). Gasoline evaporation also emits hydrocarbons. Controlling the production of NO_x, CO, and HC is important for the environment.

Exhaust Emission Requirements

The U.S. Environmental Protection Agency (EPA) and the California Air Resources Board (CARB) require that your vehicle comply with applicable exhaust, crankcase, and fuel permeation emission standards during its useful life, when operated and maintained according to the instructions provided.

CARB also requires that your vehicle comply with applicable evaporative emission requirements during its useful life, when operated and maintained according to the instructions provided.

Compliance with the terms of the Distributor's Warranties for Honda Scooter Emission Control Systems is necessary in order to maintain a valid emissions system warranty.

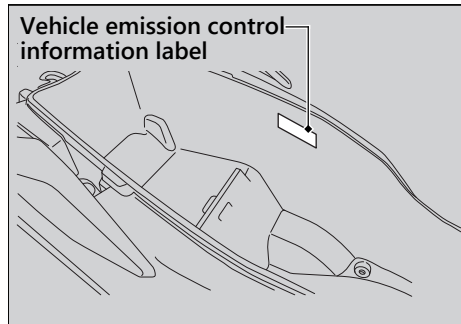

Noise Emission Requirements

The EPA requires that vehicles built after January 1, 1983 comply with applicable noise emission standards for one year or 3,730 miles (6,000 km) after the time of purchase when operated and maintained according to the instructions provided.

Exhaust Emission Control System

The exhaust emission control system includes the following components that should not need adjustment, although periodic inspection by your dealer is recommended.

PGM-FI System

The PGM-FI (programmed fuel injection) system uses sequential multiport fuel injection, and is comprised of air intake, engine control, fuel control, and exhaust control subsystems. The engine control module (ECM) uses sensors to determine how much air enters the engine, and then controls how much fuel to inject.

Ignition Timing Control System

The ignition timing control system adjusts the ignition timing to reduce the amount of HC, CO, and NO_x produced.

Catalytic Converters

The exhaust system contains one or more catalytic converters. Catalytic converters use a catalyst to convert most of the harmful exhaust gas compounds into harmless compounds.

Evaporative Emission Control System

50 STATE (meets California)

An evaporative emissions control system uses a canister filled with charcoal to adsorb fuel vapor from the fuel tank while the engine is off. The vapor is drawn into the engine and burned while riding.

Crankcase Emissions Control System

The engine is equipped with a closed crankcase system to prevent discharging crankcase emissions into the atmosphere. Blow-by gas is returned to the combustion chamber through the crankcase hose, air cleaner and the throttle body.

Fuel Permeation Emission Control

The fuel tank, fuel hoses, and fuel vapor charge hoses use fuel permeation control technologies to prevent fuel vapor emissions. Tampering with these components to reduce or defeat the effectiveness of the fuel permeation technologies is prohibited.

Noise Emission Control System

TAMPERING WITH THE NOISE CONTROL SYSTEM IS PROHIBITED:

U. S. federal law prohibits the following acts or the causing thereof: (1) The removal or rendering inoperative by any person, other than for purposes of maintenance, repair or replacement, of any device or element of design incorporated into any new vehicle for the purpose of noise control prior to its sale or delivery to the ultimate purchaser or while it is in use; or (2) the use of the vehicle after such device or element of design has been removed or rendered inoperative by any person.

AMONG THOSE ACTS PRESUMED TO CONSTITUTE TAMPERING ARE THE FOLLOWING ACTS:

- Removal of, or puncturing the muffler, baffles, header pipes or any other component which conducts exhaust gases.
- Removal of, or puncturing of any part of the intake system.
- Lack of proper maintenance.
- Removing or disabling any emissions compliance component, or replacing any compliance component with a noncompliant component.

Problems Affecting Vehicle Exhaust Emissions

Have your vehicle inspected and repaired by your dealer if you experience any of the following symptoms:

- Hard starting or stalling after starting
- Rough idling
- Misfiring or backfiring during acceleration
- Poor engine performance and poor fuel economy

Catalytic Converter

This vehicle is equipped with a three-way catalytic converter. The catalytic converter contains precious metals that serve as catalysts in high temperature chemical reactions that convert hydrocarbons (HC), carbon monoxide (CO), and oxides of nitrogen (NOx) in the exhaust gasses into safe compounds.

A defective catalytic converter contributes to air pollution and can impair your engine's performance. A replacement unit must be an original Honda part or equivalent.

Follow these guidelines to protect your vehicle's catalytic converter.

- Always use unleaded gasoline. Leaded gasoline will damage the catalytic converter.
- Keep the engine in good running condition. A poorly running engine can cause the catalytic converter to overheat causing damage to the converter or the vehicle.
- If your engine is misfiring, backfiring, stalling, or otherwise not running properly, stop riding and turn off the engine. Have your vehicle serviced as soon as possible.

Oxygenated Fuels

Some conventional fuels blended with alcohol or an ether compound are available in some locales to help reduce emissions to meet clean air standards. These gasolines are collectively referred to as oxygenated fuels. If you plan to use oxygenated fuel, check that it is unleaded and meets the minimum octane rating and blend requirement.

The following fuel blends have been approved for use in your vehicle:

- Ethanol (ethyl alcohol) up to 10% by volume.
 - ▶ Gasoline containing ethanol may be marketed under the name Gasohol.
- Do not use gasoline containing methanol (methyl alcohol).

If you accidentally fill your fuel tank with an oxygenated fuel containing higher percentages, you may experience performance problems. To resolve the problem, have your dealer drain the fuel tank and replace with the correct fuel. Fuel system or performance problems resulting from the use of an oxygenated fuel containing higher percentages are not covered by your warranty.

NOTICE

Improper use of oxygenated fuels can damage metal, rubber, and plastic parts of your fuel system.

Oxygenated fuel can also damage paint. Damage caused by spilled fuel is not covered by warranty.

If you notice any undesirable operating symptoms or performance problems, try a different brand of gasoline.

Authorized Manuals

The Service Manual used by your authorized dealer is available from your Honda dealer or Helm, Inc.

Also available, but not necessary to service your model, is the Honda Common Service Manual, which explains basic service information for various systems on Honda motorcycles, scooters, and ATV.

The Winter Storage Guide in conjunction with the Owner's Manual and Service Manual can help you prepare your Honda motorcycle, scooter, ATV, and SxS for winter storage.

These Honda manuals are written for the professional technician. However, if you possess the proper tools, observe the safety standards, and are mechanically capable, you should find them easy to use.

Special Honda tools are necessary for some procedures.

Order online: www.helminc.com

Order Toll Free: 1-888-CYCLE93

(1-888-292-5393)

(NOTE: For Credit Card Orders Only)

Monday - Friday 8:00 AM - 6:00 PM EST

Description
2021 ADV150A Service Manual
Common Service Manual (61CSM00)
Winter Storage Guide (S9507)
2021 ADV150A Owner's Manual

Warranty Coverage and Service

Coverage

Your new Honda is covered by the following warranties:

- Vehicle Limited Warranty
- Emission Control System Warranty
- Noise Control Warranty

The responsibilities, restrictions, and exclusions that apply to these warranties are explained in the Warranties Booklet given to you by your Honda dealer at the time of purchase. Always keep your Honda owner's card with your Warranties Booklet.

It is important to realize that your warranty applies only to defects in material or workmanship of your Honda. Your warranty coverage does not apply to the normal wear and deterioration associated with use of the vehicle.

Your warranty coverage is not voided if you perform your own maintenance. However, failures that occur due directly to improper maintenance are not covered by these warranties.

You can extend almost all of your warranty coverage through the Honda Protection Plan. For more information, see your Honda dealer.

Statement on Warranty Coverage for Aftermarket and Recycled Parts

New Jersey

The Magnuson-Moss Warranty Act, 15 U.S.C. s. 2301 et seq., makes it illegal for motor vehicle manufacturers to void a motor vehicle warranty or deny warranty coverage solely because an aftermarket or recycled part has been used to repair the vehicle or someone other than the authorized service provider performed service on the vehicle. This provision does not apply to a new motor vehicle purchased solely for commercial or industrial use.

Under federal law, a manufacturer may deny warranty coverage and charge for repairs to a vehicle if it is discovered that an aftermarket or recycled part installed on the vehicle is defective or was installed incorrectly and caused damage to another part of the vehicle otherwise covered under warranty. The Federal Trade Commission requires that a manufacturer demonstrate that an aftermarket or recycled part or service

performed by a person other than an authorized service provider caused damage to another part of the vehicle otherwise covered under warranty before denying warranty coverage. Additionally, federal law allows a manufacturer to void a motor vehicle warranty or deny warranty coverage if the manufacturer provides the article or service to consumers free of charge under the warranty or the manufacturer has secured a waiver from the Federal Trade Commission.

Warranty Coverage and Service

Service

Please remember that maintenance recommended in the Maintenance Schedule is not included in your warranty coverage.

If you believe you have a problem with your vehicle, call the service department of your Honda dealer. Make an appointment for an inspection and diagnosis. You will be asked to authorize that inspection, and your dealer will return the results of the inspection. If a problem exists and is covered under warranty, your dealer will perform the warranty repairs. If you have any questions about your warranty coverage or the nature of the repair, talk to the Service Manager of your Honda dealer.

If a misunderstanding occurs and you aren't satisfied with your dealer's handling of the situation, we suggest you discuss your problem with the appropriate member of the dealership's management team. If you are still not satisfied, contact the owner of the dealership or their designated representative.

Honda Contacts

American Honda Motor Co., Inc.

If you wish to contact Honda directly to comment on your experiences with your vehicle or with your dealer, please send your comments to the following address:

Powersports Customer Relations
American Honda Motor Co., Inc.,
P.O. Box 2200, Torrance,
CA 90509-2200
Mailstop: 100-4W-5F
Telephone: (866) 784-1870
Website: [https://powersports.honda.com/
contact-us](https://powersports.honda.com/contact-us)

Please include the following information in your letter:

- Name, address, and telephone number
- Product model, year, and VIN
- Date of purchase
- Dealer name and address

We will likely ask your Honda dealer to respond, or possibly acknowledge your comments directly.

Your Honda Dealer

The service department of your Honda dealer offers trained personnel to perform regular maintenance and unexpected repairs. It has the latest available service information from Honda and also handles warranty inspections and repairs.

The parts department offers Honda Genuine Parts, Pro Honda products and Honda Genuine Accessories that provide the same quality that went into your vehicle.

The sales department offers the Honda Protection Plan to extend almost all of your warranty coverage.

Reporting Safety Defects

Your Honda dealer can also supply information about, riding events, and information about safety training available in your local area.

Reporting Safety Defects

If you believe that your vehicle has a defect which could cause a crash or could cause injury or death, you should immediately inform the National Highway Traffic Safety Administration (NHTSA) in addition to notifying American Honda Motor Co., Inc.

If NHTSA receives similar complaints, it may open an investigation, and if it finds that a safety defect exists in a group of vehicles, it may order a recall and remedy campaign. However, NHTSA cannot become involved in individual problems between you, your dealer, or American Honda Motor Co., Inc.

To contact NHTSA, you may call the Vehicle Safety Hotline toll-free at:

1-888-327-4236

(TTY: 1-800-424-9153); go to

<http://www.safercar.gov>;

or write to:

Administrator, NHTSA,
1200 New Jersey Avenue, SE.,
Washington, DC 20590.

You can also obtain other information about motor vehicle safety from:

<http://www.safercar.gov>.

Specifications

■ Main Components

Overall length	77.2 in (1,960 mm)	
Overall width	29.9 in (760 mm)	
Overall height	Windscreen position	
	Lowest	45.3 in (1,150 mm)
	Highest	48.2 in (1,225 mm)
Wheelbase	52.2 in (1,325 mm)	
Minimum ground clearance	6.5 in (165 mm)	
Caster angle	26.5°	
Trail	3.3 in (85 mm)	
Curb weight	293 lb (133 kg)	
Maximum weight capacity ^{*1}	366 lb (166 kg)	
Maximum luggage weight ^{*2}	Center compartment	22 lb (10 kg)
	Front box	2.0 lb (1.0 kg)
Passenger capacity	Rider and 1 passenger	
Minimum turning radius	6.2 ft (1.90 m)	

*1: Including rider, passenger, all luggage, and accessories.

*2: Includes the weight of the luggage and added accessories.

Displacement ^{*1}	9.1 cu-in (149 cm ³)
Bore x stroke	2.26 x 2.28 in (57.3 x 57.9 mm)
Compression ratio	10.6:1
Fuel	Unleaded gasoline Recommended: 86 PON or higher
Tank capacity	2.11 US gal (8.0 L)
Battery	YTZ8V 12 V-7.0 Ah (10 HR)
Primary reduction	V-Matic (2.52:1 to 0.81:1)
Final reduction	9.854

*1: Displacement less than 9.2 cu-in (150 cm³) may have highway operating restrictions depending on state laws.

■ **Service Data**

Tire size	Front	110/80-14M/C 53P
	Rear	130/70-13M/C 57P
Tire type	Bias-ply, tubeless	
Recommended Tires	Front	IRC GP-212F
	Rear	IRC GP-212R
Tire air pressure	Front	29 psi (200 kPa, 2.00 kgf/cm ²)
	Rear	33 psi (225 kPa, 2.25 kgf/cm ²)
Minimum tread depth	Front	0.06 in (1.5 mm)
	Rear	0.08 in (2.0 mm)
Spark plug	MR8K-9 (NGK)	
Spark plug gap	(non-adjustable)	0.03 - 0.04 in (0.8 - 0.9 mm)
Idle speed	(non-adjustable)	1,700 ± 100 rpm
Recommended engine oil	Honda 4-stroke motorcycle oil API Service Classification SG or higher, excluding oils marked as "Energy Conserving" or "Resource Conserving," SAE 10W-30, JASO T 903 standard MB	
Engine oil capacity	After draining 0.8 US qt (0.8 L)	
	After draining & cleaning strainer screen 0.8 US qt (0.8 L)	
	After disassembly 1.0 US qt (0.9 L)	

Transmission oil capacity	After draining	0.13 US qt (0.12 L)
	After disassembly	0.15 US qt (0.14 L)
Recommended brake fluid	Honda DOT 3 or DOT 4 Brake Fluid	
Cooling system capacity	0.51 US qt (0.48 L)	
Recommended coolant	HONDA PRE-MIX COOLANT	

Specifications

■ Bulbs

Headlight	LED
Brake light/Taillight	LED
Front turn signal	LED
Rear turn signal	LED
License plate light	LED
Position light	LED

■ Fuses

Main fuse A	25 A
Main fuse B	15 A
Other fuse	15A, 7.5 A, 2A

Information Record

VIN	
Engine No.	
Color Label & Code	
Owner's Name	
Address	
City/State	
Phone	
Dealer's Name	
Address	
City/State	
Phone	
Service Manager	

California Proposition 65 Warning

⚠️ WARNING: Operating, servicing and maintaining a passenger vehicle or off-highway motor vehicle can expose you to chemicals including engine exhaust, carbon monoxide, phthalates, and lead, which are known to the State of California to cause cancer and birth defects or other reproductive harm. To minimize exposure, avoid breathing exhaust, do not idle the engine except as necessary, service your vehicle in a well-ventilated area and wear gloves or wash your hands frequently when servicing your vehicle. For more information go to www.P65Warnings.ca.gov/passenger-vehicle.